

ISSN 2518-170X (Online)

ISSN 2224-5278 (Print)



ҚАЙЫРЫМДЫЛЫҚ ҚОРЫ

HALYK

CHARITY FOUNDATION

«ҚАЗАҚСТАН РЕСПУБЛИКАСЫ
ҰЛТТЫҚ ҒЫЛЫМ АКАДЕМИЯСЫ» РҚБ
«ХАЛЫҚ» ЖҚ

Х А Б А Р Л А Р Ы

ИЗВЕСТИЯ

РОО «НАЦИОНАЛЬНОЙ
АКАДЕМИИ НАУК РЕСПУБЛИКИ
КАЗАХСТАН»
ЧФ «Халық»

N E W S

OF THE ACADEMY OF SCIENCES
OF THE REPUBLIC OF
KAZAKHSTAN
«Halyk» Private Foundation

SERIES

OF GEOLOGY AND TECHNICAL SCIENCES

1 (463)

JANUARY – FEBRUARY 2024

THE JOURNAL WAS FOUNDED IN 1940

PUBLISHED 6 TIMES A YEAR

ALMATY, NAS RK

NAS RK is pleased to announce that News of NAS RK. Series of geology and technical sciences scientific journal has been accepted for indexing in the Emerging Sources Citation Index, a new edition of Web of Science. Content in this index is under consideration by Clarivate Analytics to be accepted in the Science Citation Index Expanded, the Social Sciences Citation Index, and the Arts & Humanities Citation Index. The quality and depth of content Web of Science offers to researchers, authors, publishers, and institutions sets it apart from other research databases. The inclusion of News of NAS RK. Series of geology and technical sciences in the Emerging Sources Citation Index demonstrates our dedication to providing the most relevant and influential content of geology and engineering sciences to our community.

Қазақстан Республикасы Ұлттық ғылым академиясы «ҚР ҰҒА Хабарлары. Геология және техникалық ғылымдар сериясы» ғылыми журналының Web of Science-тің жаңаланған нұсқасы Emerging Sources Citation Index-те индекстелуге қабылданғанын хабарлайды. Бұл индекстелу барысында Clarivate Analytics компаниясы журналды одан әрі the Science Citation Index Expanded, the Social Sciences Citation Index және the Arts & Humanities Citation Index-ке қабылдау мәселесін қарастыруда. Web of Science зерттеушілер, авторлар, баспашылар мен мекемелерге контент тереңдігі мен сапасын ұсынады. ҚР ҰҒА Хабарлары. Геология және техникалық ғылымдар сериясы Emerging Sources Citation Index-ке енуі біздің қоғамдастық үшін ең өзекті және беделді геология және техникалық ғылымдар бойынша контентке адалдығымызды білдіреді.

НАНПК сообщает, что научный журнал «Известия НАНПК. Серия геологии и технических наук» был принят для индексирования в Emerging Sources Citation Index, обновленной версии Web of Science. Содержание в этом индексировании находится в стадии рассмотрения компанией Clarivate Analytics для дальнейшего принятия журнала в the Science Citation Index Expanded, the Social Sciences Citation Index и the Arts & Humanities Citation Index. Web of Science предлагает качество и глубину контента для исследователей, авторов, издателей и учреждений. Включение Известия НАНПК. Серия геологии и технических наук в Emerging Sources Citation Index демонстрирует нашу приверженность к наиболее актуальному и влиятельному контенту по геологии и техническим наукам для нашего сообщества.



ЧФ «ХАЛЫҚ»

В 2016 году для развития и улучшения качества жизни казахстанцев был создан частный Благотворительный фонд «Халык». За годы своей деятельности на реализацию благотворительных проектов в областях образования и науки, социальной защиты, культуры, здравоохранения и спорта, Фонд выделил более 45 миллиардов тенге.

Особое внимание Благотворительный фонд «Халык» уделяет образовательным программам, считая это направление одним из ключевых в своей деятельности. Оказывая поддержку отечественному образованию, Фонд вносит свой посильный вклад в развитие качественного образования в Казахстане. Тем самым способствуя росту числа людей, способных менять жизнь в стране к лучшему – профессионалов в различных сферах, потенциальных лидеров и «великих умов». Одной из значимых инициатив фонда «Халык» в образовательной сфере стал проект *Ozgeris powered by Halyk Fund* – первый в стране бизнес-инкубатор для учащихся 9-11 классов, который помогает развивать необходимые в современном мире предпринимательские навыки. Так, на содействие малому бизнесу школьников было выделено более 200 грантов. Для поддержки талантливых и мотивированных детей Фонд неоднократно выделял гранты на обучение в Международной школе «Мирас» и в Astana IT University, а также помог казахстанским школьникам принять участие в престижном конкурсе «USTEM Robotics» в США. Авторские работы в рамках проекта «Тәлімгер», которому Фонд оказал поддержку, легли в основу учебной программы, учебников и учебно-методических книг по предмету «Основы предпринимательства и бизнеса», преподаваемого в 10-11 классах казахстанских школ и колледжей.

Помимо помощи школьникам, учащимся колледжей и студентам Фонд считает важным внести свой вклад в повышение квалификации педагогов, совершенствование их знаний и навыков, поскольку именно они являются проводниками знаний будущих поколений казахстанцев. При поддержке Фонда «Халык» в южной столице был организован ежегодный городской конкурс педагогов «Almaty Digital Ustaz».

Важной инициативой стал реализуемый проект по обучению основам финансовой грамотности преподавателей из восьми областей Казахстана, что должно оказать существенное влияние на воспитание финансовой грамотности и предпринимательского мышления у нового поколения граждан страны.

Необходимую помощь Фонд «Халык» оказывает и тем, кто особенно остро в ней нуждается. В рамках социальной защиты населения активно проводится

работа по поддержке детей, оставшихся без родителей, детей и взрослых из социально уязвимых слоев населения, людей с ограниченными возможностями, а также обеспечению нуждающихся социальным жильем, строительству социально важных объектов, таких как детские сады, детские площадки и физкультурно-оздоровительные комплексы.

В копилку добрых дел Фонда «Халык» можно добавить оказание помощи детскому спорту, куда относится поддержка в развитии детского футбола и карате в нашей стране. Жизненно важную помощь Благотворительный фонд «Халык» оказал нашим соотечественникам во время недавней пандемии COVID-19. Тогда, в разгар тяжелой борьбы с коронавирусной инфекцией Фонд выделил свыше 11 миллиардов тенге на приобретение необходимого медицинского оборудования и дорогостоящих медицинских препаратов, автомобилей скорой медицинской помощи и средств защиты, адресную материальную помощь социально уязвимым слоям населения и денежные выплаты медицинским работникам.

В 2023 году наряду с другими проектами, нацеленными на повышение благосостояния казахстанских граждан Фонд решил уделить особое внимание науке, поскольку она является частью общественной культуры, а уровень ее развития определяет уровень развития государства.

Поддержка Фондом выпуска журналов Национальной Академии наук Республики Казахстан, которые входят в международные фонды Scopus и Wos и в которых публикуются статьи отечественных ученых, докторантов и магистрантов, а также научных сотрудников высших учебных заведений и научно-исследовательских институтов нашей страны является не менее значимым вкладом Фонда в развитие казахстанского общества.

**С уважением,
Благотворительный Фонд «Халык»!**

Бас редактор

ЖҰРЫНОВ Мұрат Жұрынұлы, химия ғылымдарының докторы, профессор, ҚР ҰҒА академигі, «Қазақстан Республикасы Ұлттық ғылым академиясы» РҚБ-нің президенті, АҚ «Д.В. Сокольский атындағы отын, катализ және электрохимия институтының» бас директоры (Алматы, Қазақстан) **Н = 4**

Ғылыми хатшы

АБСАДЫКОВ Бахыт Нарикбайұлы, техника ғылымдарының докторы, профессор, ҚР ҰҒА жауапты хатшысы, А.Б. Бектұров атындағы химия ғылымдары институты (Алматы, Қазақстан) **Н = 5**

Редакциялық алқа:

ӘБСАМЕТОВ Мәліс Құдысұлы (бас редактордың орынбасары), геология-минералогия ғылымдарының докторы, профессор, ҚР ҰҒА академигі, «У.М. Ахмедсафина атындағы гидрогеология және геоэкология институтының» директоры (Алматы, Қазақстан) **Н = 2**

ЖОЛТАЕВ Герой Жолтайұлы (бас редактордың орынбасары), геология-минералогия ғылымдарының докторы, профессор, Қ.И. Сатпаев атындағы геология ғылымдары институтының директоры (Алматы, Қазақстан) **Н = 2**

СНОУ Дэниел, Ph.D, қауымдастырылған профессор, Небраска университетінің Су ғылымдары зертханасының директоры (Небраска штаты, АҚШ) **Н = 32**

ЗЕЛЬТМАН Реймар, Ph.D, табиғи тарих мұражайының Жер туралы ғылымдар бөлімінде петрология және пайдалы қазбалар кен орындары саласындағы зерттеулердің жетекшісі (Лондон, Англия) **Н = 37**

ПАНФИЛОВ Михаил Борисович, техника ғылымдарының докторы, Нанси университетінің профессоры (Нанси, Франция) **Н = 15**

ШЕН Пин, Ph.D, Қытай геологиялық қоғамының тау геологиясы комитеті директорының орынбасары, Американдық экономикалық геологтар қауымдастығының мүшесі (Пекин, Қытай) **Н = 25**

ФИШЕР Аксель, Ph.D, Дрезден техникалық университетінің қауымдастырылған профессоры (Дрезден, Берлин) **Н = 6**

КОНТОРОВИЧ Алексей Эмильевич, геология-минералогия ғылымдарының докторы, профессор, РҒА академигі, А.А. Трофимука атындағы мұнай-газ геологиясы және геофизика институты (Новосибирск, Ресей) **Н = 19**

АГАБЕКОВ Владимир Енокович, химия ғылымдарының докторы, Беларусь ҰҒА академигі, Жаңа материалдар химиясы институтының құрметті директоры (Минск, Беларусь) **Н = 13**

КАТАЛИН Стефан, Ph.D, Дрезден техникалық университетінің қауымдастырылған профессоры (Дрезден, Берлин) **Н = 20**

СЕЙТМҰРАТОВА Элеонора Юсуповна, геология-минералогия ғылымдарының докторы, профессор, ҚР ҰҒА корреспондент-мүшесі, Қ.И. Сатпаев атындағы Геология ғылымдары институты зертханасының меңгерушісі (Алматы, Қазақстан) **Н = 11**

САҒЫНТАЕВ Жанай, Ph.D, қауымдастырылған профессор, Назарбаев университеті (Нұр-Сұлтан, Қазақстан) **Н = 11**

ФРАТТИНИ Паоло, Ph.D, Бикокк Милан университеті қауымдастырылған профессоры (Милан, Италия) **Н = 28**

«ҚР ҰҒА» РҚБ Хабарлары. Геология және техникалық ғылымдар сериясы».

ISSN 2518-170X (Online),

ISSN 2224-5278 (Print)

Меншіктеуші: «Қазақстан Республикасының Ұлттық ғылым академиясы» РҚБ (Алматы қ.).

Қазақстан Республикасының Ақпарат және қоғамдық даму министрлігінің Ақпарат комитетінде 29.07.2020 ж. берілген № **KZ39VPU00025420** мерзімдік басылым тіркеуіне қойылу туралы куәлік.

Тақырыптық бағыты: *геология, мұнай және газды өңдеудің химиялық технологиялары, мұнай химиясы, металдарды алу және олардың қосындыларының технологиясы.*

Мерзімділігі: жылына 6 рет.

Тиражы: 300 дана.

Редакцияның мекен-жайы: 050010, Алматы қ., Шевченко көш., 28, 219 бөл., тел.: 272-13-19

<http://www.geolog-technical.kz/index.php/en/>

© «Қазақстан Республикасының Ұлттық ғылым академиясы» РҚБ, 2024

Главный редактор

ЖУРИНОВ Мурат Журинович, доктор химических наук, профессор, академик НАН РК, президент РОО «Национальной академии наук Республики Казахстан», генеральный директор АО «Институт топлива, катализа и электрохимии им. Д.В. Сокольского» (Алматы, Казахстан) **Н = 4**

Ученый секретарь

АБСАДЫКОВ Бахыт Нарикбаевич, доктор технических наук, профессор, ответственный секретарь НАН РК, Институт химических наук им. А.Б. Бектурова (Алматы, Казахстан) **Н = 5**

Редакционная коллегия:

АБСАМЕТОВ Малис Кудысович, (заместитель главного редактора), доктор геологоминералогических наук, профессор, академик НАН РК, директор Института гидрогеологии и геоэкологии им. У.М. Ахмедсафина (Алматы, Казахстан) **Н = 2**

ЖОЛТАЕВ Герой Жолтаевич, (заместитель главного редактора), доктор геологоминералогических наук, профессор, директор Института геологических наук им. К.И. Сатпаева (Алматы, Казахстан) **Н=2**

СНОУ Дэниел, Ph.D, ассоциированный профессор, директор Лаборатории водных наук университета Небраски (штат Небраска, США) **Н = 32**

ЗЕЛЬТМАН Реймар, Ph.D, руководитель исследований в области петрологии и месторождений полезных ископаемых в Отделе наук о Земле Музея естественной истории (Лондон, Англия) **Н = 37**

ПАНФИЛОВ Михаил Борисович, доктор технических наук, профессор Университета Нанси (Нанси, Франция) **Н=15**

ШЕН Пин, Ph.D, заместитель директора Комитета по горной геологии Китайского геологического общества, член Американской ассоциации экономических геологов (Пекин, Китай) **Н = 25**

ФИШЕР Аксель, ассоциированный профессор, Ph.D, технический университет Дрезден (Дрезден, Берлин) **Н = 6**

КОНТОРОВИЧ Алексей Эмильевич, доктор геолого-минералогических наук, профессор, академик РАН, Институт нефтегазовой геологии и геофизики им. А.А. Трофимука СО РАН (Новосибирск, Россия) **Н = 19**

АГАБЕКОВ Владимир Енокович, доктор химических наук, академик НАН Беларуси, почетный директор Института химии новых материалов (Минск, Беларусь) **Н = 13**

КАТАЛИН Стефан, Ph.D, ассоциированный профессор, Технический университет (Дрезден, Берлин) **Н = 20**

СЕЙТМУРАТОВА Элеонора Юсуповна, доктор геолого-минералогических наук, профессор, член-корреспондент НАН РК, заведующая лабораторией Института геологических наук им. К.И. Сатпаева (Алматы, Казахстан) **Н=11**

САГИНТАЕВ Жанай, Ph.D, ассоциированный профессор, Назарбаев университет (Нурсултан, Казахстан) **Н = 11**

ФРАТТИНИ Паоло, Ph.D, ассоциированный профессор, Миланский университет Бикокк (Милан, Италия) **Н = 28**

«Известия РОО «НАН РК». Серия геологии и технических наук».

ISSN 2518-170X (Online),

ISSN 2224-5278 (Print)

Собственник: Республиканское общественное объединение «Национальная академия наук Республики Казахстан» (г. Алматы).

Свидетельство о постановке на учет периодического печатного издания в Комитете информации Министерства информации и общественного развития Республики Казахстан № **KZ39VPY00025420**, выданное 29.07.2020 г.

Тематическая направленность: *геология, химические технологии переработки нефти и газа, нефтехимия, технологии извлечения металлов и их соединений.*

Периодичность: 6 раз в год.

Тираж: 300 экземпляров.

Адрес редакции: 050010, г. Алматы, ул. Шевченко, 28, оф. 219, тел.: 272-13-19

<http://www.geolog-technical.kz/index.php/en/>

© РОО «Национальная академия наук Республики Казахстан», 2024

Editorial chief

ZHURINOV Murat Zhurinovich, doctor of chemistry, professor, academician of NAS RK, president of the National Academy of Sciences of the Republic of Kazakhstan, general director of JSC “Institute of fuel, catalysis and electrochemistry named after D.V. Sokolsky» (Almaty, Kazakhstan) **H = 4**

Scientific secretary

ABSADYKOV Bakhyt Narikbaevich, doctor of technical sciences, professor, executive secretary of NAS RK, Bekturov Institute of chemical sciences (Almaty, Kazakhstan) **H = 5**

Editorial board:

ABSAMETOV Malis Kudysovich, (deputy editor-in-chief), doctor of geological and mineralogical sciences, professor, academician of NAS RK, director of the Akhmedsafin Institute of hydrogeology and hydrophysics (Almaty, Kazakhstan) **H=2**

ZHOLTAEV Geroy Zholtaevich, (deputy editor-in-chief), doctor of geological and mineralogical sciences, professor, director of the institute of geological sciences named after K.I. Satpayev (Almaty, Kazakhstan) **H=2**

SNOW Daniel, Ph.D, associate professor, director of the laboratory of water sciences, Nebraska University (Nebraska, USA) **H = 32**

ZELTMAN Reyman, Ph.D, head of research department in petrology and mineral deposits in the Earth sciences section of the museum of natural history (London, England) **H = 37**

PANFILOV Mikhail Borisovich, doctor of technical sciences, professor at the Nancy University (Nancy, France) **H=15**

SHEN Ping, Ph.D, deputy director of the Committee for Mining geology of the China geological Society, Fellow of the American association of economic geologists (Beijing, China) **H = 25**

FISCHER Axel, Ph.D, associate professor, Dresden University of technology (Dresden, Germany) **H=6**

KONTOROVICH Aleksey Emilievich, doctor of geological and mineralogical sciences, professor, academician of RAS, Trofimuk Institute of petroleum geology and geophysics SB RAS (Novosibirsk, Russia) **H = 19**

AGABEKOV Vladimir Enokovich, doctor of chemistry, academician of NAS of Belarus, honorary director of the Institute of chemistry of new materials (Minsk, Belarus) **H = 13**

KATALIN Stephan, Ph.D, associate professor, Technical university (Dresden, Berlin) **H = 20**

SEITMURATOVA Eleonora Yusupovna, doctor of geological and mineralogical sciences, professor, corresponding member of NAS RK, head of the laboratory of the Institute of geological sciences named after K.I. Satpayev (Almaty, Kazakhstan) **H=11**

SAGINTAYEV Zhanay, Ph.D, associate professor, Nazarbayev University (Nursultan, Kazakhstan) **H = 11**

FRATTINI Paolo, Ph.D, associate professor, university of Milano-Bicocca (Milan, Italy) **H = 28**

News of the National Academy of Sciences of the Republic of Kazakhstan. Series of geology and technology sciences.

ISSN 2518-170X (Online),

ISSN 2224-5278 (Print)

Owner: RPA «National Academy of Sciences of the Republic of Kazakhstan» (Almaty).

The certificate of registration of a periodical printed publication in the Committee of information of the Ministry of Information and Social Development of the Republic of Kazakhstan **No. KZ39VPY00025420**, issued 29.07.2020.

Thematic scope: *geology, chemical technologies for oil and gas processing, petrochemistry, technologies for extracting metals and their connections.*

Periodicity: 6 times a year.

Circulation: 300 copies.

Editorial address: 28, Shevchenko str., of. 219, Almaty, 050010, tel. 272-13-19

<http://www.geolog-technical.kz/index.php/en/>

© National Academy of Sciences of the Republic of Kazakhstan, 2024

NEWS of the National Academy of Sciences of the Republic of Kazakhstan
SERIES OF GEOLOGY AND TECHNICAL SCIENCES
ISSN 2224–5278
Volume 1. Number 463 (2024), 80–94
<https://doi.org/10.32014/2024.2518-170X.367>

UDC 502.174.1

© **A.A. Volnenko¹, A.E. Leudanski², A.S. Serikov¹, A.N. Issayeva¹,
D.K. Zhumadullayev^{1*}, 2024**

¹M. Auezov South Kazakhstan University, Shymkent, Kazakhstan;

²Belorussian State Technological University, Minsk, Belarus.

E-mail: daulet_ospl@mail.ru

CALCULATION AND IMPLEMENTATION OF A CYCLONE-VORTEX DEVICE IN CHROMIC SULPHATE PRODUCTION

Volnenko A.A. — Doctor of Technical Sciences, Professor of the Department of Technological Machines and Equipment, M.Auezov South Kazakhstan University

E-mail: nii_mm@mail.ru, <https://orcid.org/0000-0001-6800-9675>;

Leudanski A.E. — Doctor of Technical Sciences, Associate Professor of the Department "Processes and Apparatuses of Chemical Production", Belorussian State Technological University

E-mail: alex_levdansky@mail.ru., <https://orcid.org/0000-0003-2684-7771>;

Serikov A.S. — Master, doctoral student of the Department of Technological Machines and Equipment, M.Auezov South Kazakhstan University

E-mail: Ablay.s.94@mail.ru, <https://orcid.org/0009-0004-2236-9455>;

Issayeva A.N. — PhD, senior teacher of the Department of Ecology, M.Auezov South Kazakhstan University

E-mail: isaeva.aika@mail.ru, <https://orcid.org/0000-0002-4833-1904>;

Zhumadullayev D.K. — PhD, senior teacher of the Department of Technological Machines and Equipment, M.Auezov South Kazakhstan University

E-mail: daulet_ospl@mail.ru, <https://orcid.org/0000-0002-6552-2817>.

Abstract. Traditional gas cleaning schemes are mainly equipped with separate gas cleaning devices that perform the functions of ensuring a given efficiency in cleaning from dust particles and gas components. In this regard, the creation of combined apparatuses combining several zones for carrying out various processes in one apparatus is in demand. Analysis of the operation of combined gas purification devices for purifying multicomponent gases made it possible to develop the design of a cyclone-vortex action device, in the lower zone of which a centrifugal mechanism for collecting dust is realized, and in the upper zone – vortex interaction of a gas-liquid flow in the volume of a regular packing, which provides absorption cleaning. The development and implementation of such devices seems to be relevant. In the manufacture of a laboratory installation, the structural ratios of the cyclone and packed stages of the apparatus of cyclone-vortex action were obtained based on the recommendations for the manufacture of cyclones, as well as the results of research and recommendations for the design of apparatuses with

a regular movable nozzle. In the process of research, standard methods for determining the hydraulic resistance and dust collection efficiency were used. Based on the results of laboratory studies, the main calculated dependences of the hydraulic resistance and dust collection parameters of the cyclone and packed stages and the device as a whole were obtained, which, along with the recommendations, were used to calculate and design an industrial device. The cyclone-vortex action device was tested in industrial conditions and implemented in the technological scheme for the purification of gases leaving the boiling bed dryer in chromic sulfate production at Aktobe Plant of Chromic Compounds JSC. According to the results of industrial tests, it was noted that in the cyclone part, the increase in hydraulic resistance with an increase in gas velocity is due to an increase in dynamic pressure and losses associated with a change in the direction of gas movement and friction losses. The effective force acting on suspended solids is the centrifugal force, the magnitude of which is largely determined by the velocity of the gas flow. In the packed zone, the operation of the apparatus proceeds in a drop mode, characterized by a uniform distribution of flows over the cross section of the apparatus, an increase in the turbulence of the gas-liquid flow, and an increase in the intensity and frequency of pulsations. This contributes to an increase in the efficiency of dust collection.

Keywords: gas purification device, cyclone-vortex device, hydraulic resistance, dust collection efficiency, gas velocity, industrial tests, implementation

© А.А. Волненко¹, А.Э. Левданский², А. С. Сериков¹, А.Н. Исаева¹,
Д.К. Жумадуллаев^{1*}, 2024

¹М. Әуезов атындағы Оңтүстік Қазақстан университеті, Шымкент, Қазақстан;

²Беларусь мемлекеттік технологиялық университет, Минск, Беларусь.

E-mail: daulet_ospl@mail.ru

ХРОМ СУЛЬФАТЫН ӨНДІРУДЕ ЦИКЛОНДЫ-ҚҰЙЫНДЫ АППАРАТТЫ ЕСЕПТЕУ ЖӘНЕ ЕНГІЗУ

Волненко А.А. — техника ғылымдарының докторы, Технологиялық машиналар және жабдықтар кафедрасының процессоры, М.Әуезов атындағы Оңтүстік Қазақстан университеті

E-mail: nii_mm@mail.ru, <https://orcid.org/0000-0001-6800-9675>;

Левданский А.Э. — техника ғылымдарының докторы, Химия өндірісіндегі процестермен аппараттары кафедрасының профессоры, Беларусь мемлекеттік технологиялық университеті

E-mail: alex_levdansky@mail.ru, <https://orcid.org/0000-0003-2684-7771>;

Сериков А.С. — магистр, Технологиялық машиналар және жабдықтар кафедрасының докторанты, М. Әуезов атындағы Оңтүстік Қазақстан университеті

E-mail: Ablay.s.94@mail.ru, <https://orcid.org/0009-0004-2236-9455>;

Исаева А.Н. — PhD, Экология кафедрасының аға оқытушысы, М. Әуезов атындағы Оңтүстік Қазақстан университеті.

E-mail: isaeva.aika@mail.ru, <https://orcid.org/0000-0002-4833-1904>;

Жумадуллаев Д.К. — PhD, Технологиялық машиналар және жабдықтар кафедрасының аға оқытушысы, М. Әуезов атындағы Оңтүстік Қазақстан университеті

E-mail: daulet_ospl@mail.ru, <https://orcid.org/0000-0002-6552-2817>.

Аннотация. Газды тазартудың дәстүрлі сұлбалары негізінен шаң бөлшектері мен газ компоненттерінен тазартудың берілген тиімділігін қамтамасыз ету функцияларын орындайтын жеке газ тазарту аппараттарымен жабдықталған. Осыған байланысты бір аппаратта әртүрлі процестерді жүргізу үшін бірнеше аймақтарды біріктіретін біріктірілген аппараттарды құру сұранысқа ие. Көп компонентті газдарды тазартуға арналған қолданыстағы біріктірілген газ тазарту аппараттарының жұмысын талдау циклонды-құйынды әсер ететін аппараттың конструкциясын әзірлеуге мүмкіндік берді, оның төменгі аймағында шаңды ұстаудың орталықтан тепкіш механизмі, ал жоғарғы жағында – сіңіргіш (абсорбциялық) тазалауды қамтамасыз ететін тұрақты саптама көлеміндегі газ-сұйықтық ағынының құйынды өзара әрекеттесуі жүзеге асырылады. Мұндай аппараттарды әзірлеу және енгізу өзекті болып көрінеді. Зертханалық қондырғыны дайындау кезінде циклонды-құйынды әсер ететін аппараттың циклондық және саптамалық сатыларының конструктивтік арақатынасы циклондарды дайындау жөніндегі ұсынымдарға, сондай-ақ зерттеу нәтижелеріне және тұрақты жылжымалы саптамасы бар аппараттарды жобалау жөніндегі ұсынымдарға сүйене отырып алынды. Зерттеу барысында гидравликалық кедергілер мен шаң аулаудың тиімділігін анықтаудың стандартты әдістері қолданылды. Зертханалық зерттеулердің нәтижелері негізінде гидравликалық кедергінің және циклондық және саптамалық сатылардың және тұтастай алғанда аппараттың шаң аулау параметрлерінің негізгі есептік тәуелділіктері алынды, олар ұсыныстармен қатар өнеркәсіптік аппаратты есептеу және жобалау үшін пайдаланылды. Циклонды-құйынды әсер ететін аппарат өнеркәсіптік жағдайларда сыналды және "Ақтөбе хром қосылыстары зауыты" АҚ-да хром сульфатын өндіруде қайнаған қабатты кептіргіштен шығатын газдарды тазартудың технологиялық схемасына енгізілді. Өнеркәсіптік сынақтардың нәтижелері бойынша циклон бөлігінде газ жылдамдығының жоғарылауы кезінде гидравликалық кедергінің өсуі динамикалық қысымның өсуіне және газдың қозғалыс бағытының өзгеруіне және үйкеліс шығындарына байланысты шығындарға байланысты екендігі атап өтілді. Қатты қалқыма бөлшектерге әсер ететін тиімді күш-бұл ортадан тепкіш күш, оның мәні негізінен газ ағынының жылдамдығына байланысты. Саптама аймағында аппараттың жұмысы ағындардың аппараттың көлденең қимасы бойынша біркелкі бөлінуімен, газ-сұйықтық ағынының турбуленттілігінің өсуімен, пульсация жиілігінің қарқындылығымен және ұлғаюымен сипатталатын тамшы режимінде жүреді. Бұл шаң аулау тиімділігінің артуына ықпал етеді.

Түйін сөздер: газ тазалау аппараты, циклонды-құйынды аппарат, гидравликалық кедергі, шаң аулау тиімділігі, газ жылдамдығы, өнеркәсіптік сынақтар, енгізу

© А.А. Волненко¹, А.Э. Левданский², А.С. Сериков¹, А.Н. Исаева¹,
Д.К. Жумадуллаев^{1*}, 2024

¹Южно-Казахстанский университет им. М. Ауэзова, Шымкент, Казахстан;

²Белорусский государственный технологический университет, Минск, Беларусь.

E-mail: daulet_ospl@mail.ru

РАСЧЕТ И ВНЕДРЕНИЕ ЦИКЛОННО-ВИХРЕВОГО АППАРАТА В ПРОИЗВОДСТВЕ СУЛЬФАТА ХРОМА

Волненко А.А. — доктор технических наук, профессор кафедры Технологические машины и оборудование, Южно-Казахстанский университет им. М. Ауэзова

E-mail: nii_mm@mail.ru, <https://orcid.org/0000-0001-6800-9675>;

Левданский А.Э. — доктор технических наук, доцент кафедры «Процессы и аппараты химических производств», Белорусский государственный технологический университет

E-mail: alex_levdansky@mail.ru., <https://orcid.org/0000-0003-2684-7771>;

Сериков А.С. — магистр, докторант кафедры Технологические машины и оборудование, Южно-Казахстанский университет им. М.Ауэзова

E-mail: Ablay.s.94@mail.ru, <https://orcid.org/0009-0004-2236-9455>;

Исаева А.Н. — PhD, старший преподаватель кафедры Экология, Южно-Казахстанский университет им. М. Ауэзова

E-mail: isaeva.aika@mail.ru, <https://orcid.org/0000-0002-4833-1904>;

Жумадуллаев Д.К. — PhD, старший преподаватель кафедры «Технологические машины и оборудование», Южно-Казахстанский университет им. М. Ауэзова

E-mail: daulet_ospl@mail.ru, <https://orcid.org/0000-0002-6552-2817>.

Аннотация. Традиционные схемы очистки газов оснащены в основном отдельными газоочистными аппаратами, выполняющих функции по обеспечению заданной эффективности по очистке от пылевых частиц и газовых компонентов. В этой связи востребованным является создание комбинированных аппаратов сочетающих несколько зон для проведения различных процессов в одном аппарате. Анализ работы существующих комбинированных газоочистных аппаратов для очистки многокомпонентных газов позволил разработать конструкцию аппарата циклонно-вихревого действия, в нижней зоне которого реализуется центробежный механизм улавливания пыли, а в верхней – вихревое взаимодействие газожидкостного потока в объеме регулярной насадки, обеспечивающего абсорбционную очистку. Разработка и внедрение таких аппаратов представляется актуальной. При изготовлении лабораторной установки конструктивные соотношения циклонной и насадочной ступеней аппарата циклонно-вихревого действия получены исходя из рекомендаций по изготовлению циклонов, а также результатов исследований и рекомендаций по проектированию аппаратов с регулярной подвижной насадкой. В процессе исследований использовались стандартные методы определения гидравлического сопротивления и эффективности пылеулавливания. На основе результатов лабораторных исследований получены основные расчетные зависимости гидравлического сопротивления и параметров пылеулавливания циклонной и насадочной ступеней и аппарата в целом, которые наряду с рекомендациями были

использованы для расчета и проектирования промышленного аппарата. Аппарат циклонно-вихревого действия был испытан в промышленных условиях и внедрен в технологической схеме очистки газов, отходящих от сушилки кипящего слоя в производстве сульфата хрома на АО «Актюбинский завод хромовых соединений». По результатам промышленных испытаний отмечено, что в циклонной части рост гидравлического сопротивления при увеличении скорости газа обусловлен ростом динамического напора и потерями, связанными с изменением направления движения газа и потерями на трение. Эффективной силой, воздействующей на взвешенные твердые частицы, является центробежная сила, величина которой в значительной степени обуславливается скоростью газового потока. В насадочной зоне работа аппарата протекает в капельном режиме, характеризующимся однородностью распределения потоков по поперечному сечению аппарата, ростом турбулентности газожидкостного потока, интенсивностью и увеличением частоты пульсаций. Это способствует росту эффективности пылеулавливания.

Ключевые слова: газоочистной аппарат, циклонно-вихревой аппарат, гидравлическое сопротивление, эффективность пылеулавливания, скорость газа, промышленные испытания, внедрение

Introduction

The existing technological gas purification schemes provide for installation of separate devices in which dust collection and absorption processes are carried out sequentially, as well as combined devices combining several zones for carrying out different processes in one device. In this connection, schemes with combined devices are often preferred due to their compactness and low material consumption.

Combined devices include inertial-turbulent devices with a movable (regular) packing (Tarat et.al., 1979: 208; Strauss, 1974: 392; Ramatullayeva, 2009: 113), which implement shock interaction of the gas flow with the liquid mirror and vortex interaction in the regular packed zone. In these devices, one and the same absorbing solution is used in the dust collection and absorption zones. This is not always appropriate. So, for example, when trapping soluble dust, simultaneous absorption of gaseous components is difficult due to a decrease in the gas solubility.

This problem is solved in the design of a combined device with autonomous irrigation circuits, separately for each of the zones – shock-inertial and packed, which prevent the formation of deposits and increase the driving force of the absorption process (Khussanov, 2011: 141). At the same time, this device has significant hydraulic resistance.

For separate carrying out of dust collection and absorption processes, we have developed a design of a cyclone-vortex action device (Issayeva et al., 2021: 8), in the lower zone of which a centrifugal mechanism of dust collection is realized in the absence of irrigation with a liquid, and in the upper zone there is a vortex interaction of a gas-liquid flow in the volume of a regular packing.

The purpose of the article is to obtain a methodology for calculating the hydraulic resistance and dust collection parameters of the cyclone and packed stages and the

cyclone-vortex device as a whole, as well as to analyze the results obtained in the process of industrial tests and the introduction of this device in the technological scheme for purifying gases leaving the boiling bed dryer in production of chromic sulfate at Aktobe Plant of Chromic Compounds JSC.

The research methodology included standard methods for determining hydraulic resistance and dust collection efficiency.

Materials and methods

The experimental plant for conducting studies of hydraulic resistance and dust collection efficiency included a cyclone-vortex dust collector, a fan, a pump, circulation and pressure liquid containers for irrigating the upper contact stage, a container for collecting dry dust from the lower contact stage, a compressor for spraying dust at the dust collector inlet.

In all experiments, the dust concentration at the inlet to the device was maintained at about 2 g/m³. KP-3 dusty quartz, additionally milled in a vibrating mill, was used as the standard dust.

When determining the overall dust collection efficiency, the internal filtration method was used (Gordon et.al., 1977: 456). Glass wool was used to fill the allonge. The gas consumption through the allonge was set based on the condition of isokinetic sampling. To measure the dispersed composition of dust in a gas flow, an impactor was used instead of allonges (Rusakov et. al., 1970: 52).

The hydraulic resistance of the device ΔP was measured by a differential pressure gauge and controlled by a DSR-type device.

Research results

The basis for creating the design of the cyclone-vortex action device (Issayeva et al., 2021: 7; Torskiy et.al., 2018: 8) was the recommendations for the manufacture of cyclones mainly of the design of NIIOGAZ (Shvydkiy et. al., 2002: 640; Vetoshkin, 2005: 210), as well as the research results and recommendations for the design of devices with a regular movable packing (Volnenko, 2018: 176), ITPN, UID with RPN (Balabekov, 2018: 184), device with shock-vortex interaction of flows, combined gas-liquid device with autonomous irrigation circuits (Khussanov, 2011: 141).

The recommended design ratios of the cyclone-vortex action device were: For the cyclone stage (here D is the diameter of the cylindrical part of the device):

- the inner diameter of the exhaust pipe $d = 0.59D$;
- the inner diameter of the dust outlet $d_1 = 0.4D$;
- the width of the inlet fitting in the cyclone part (internal dimension) $b = 0.2D$;
- the width of the inlet fitting at the inlet (internal dimension) $b_1 = 0.26D$;
- the length of the inlet fitting $l = 0.6D$;
- the height of the plant flange $h_{pf} = 0.1D$;
- the angle of inclination of the cover and inlet fitting $\alpha = 15^\circ$;
- the height of the inlet fitting (internal dimension) $a = 0.66D$;
- the height of the exhaust pipe $h_p = 1.74D$;
- the height of the cylindrical part $H_{cl} = 2.26D$;
- the height of the cone $H_{cn} = 2D$;

- the height of the outer part of the exhaust pipe $h_{op}=0.3D$;
- the total height of the cyclone part of the device $H_{cp} = 4.56D$.

For the vortex stage:

- the vertical pitch between the packed elements $t_v/b=2$;
- the horizontal pitch between the packed elements horizontally $t_r/b = 2$;
- the size of the packed elements (plates) $b \times b \times \delta = 40 \times 40 \times 1$ mm;
- the height of the packed zone $H_L = 2.5D$.

The total height of the device $H_{ap} = 9.75D$.

The laboratory plant included a device $D = 400$ mm.

Based on the results of laboratory studies, the main calculated dependences of the hydrodynamic characteristics and dust collection parameters were obtained.

To calculate the total hydraulic resistance of the device, the following formula was obtained (Zhumadullayev et.al., 2020: 7):

$$\Delta P_{ap} = \Delta P_{cp} + \Delta P_L, \quad (1)$$

where ΔP_{cp} – the hydraulic resistance of the cyclone stage, Pa; ΔP_L – the hydraulic resistance of the packed zone, Pa.

The hydraulic resistance of the cyclone stage is determined by the equation:

$$\Delta P_{cp} = \Delta P_{in} + \Delta P_{az} + \Delta P_{out}, \quad (2)$$

where P_{in} – the hydraulic resistance of the inlet section, Pa; ΔP_{az} – the hydraulic resistance of the annular zone, Pa; ΔP_{out} – the hydraulic resistance of the outlet section, Pa.

The hydraulic resistance of the inlet section:

$$\Delta P_{in} = \xi_{in} \cdot \frac{\rho g \cdot w_{in}^2}{2}, \quad (3)$$

where $\xi_{in} = 3,32$ – the resistance coefficient at the gas inlet; w_{in} – the gas velocity at the inlet, m/s.

The hydraulic resistance of the annular zone:

$$\Delta P_{az} = \xi_{az} \cdot \frac{\rho g \cdot w_{az}^2}{2}, \quad (4)$$

where $\xi_{az} = 4,1$ – the resistance coefficient when passing the annular gap; w_{az} – the gas velocity in the annular gap, m/s.

The hydraulic resistance of the outlet section:

$$\Delta P_{out} = \xi_{out} \cdot \frac{\rho g \cdot w_{out}^2}{2}, \quad (5)$$

where $\xi_{out} = 5,7$ – the resistance coefficient at the gas outlet; w_{out} – the gas velocity at the outlet, m/s.

The hydraulic resistance of the packed zone is determined by the formula used to calculate devices with a regular movable packing (Balabekov, 2018: 184):

$$\Delta P_L = \xi_L \frac{H}{t_v} \cdot \frac{\rho_g \cdot W_g^2}{2\varepsilon_0^2} \quad (6)$$

Here H – the height of the packed zone, m; ε_0 – the porosity of the packing:

$$\varepsilon_0 = 1 - \left(\frac{b}{t_r}\right)^2 \quad (7)$$

The resistance coefficient of the irrigation packing takes into account the degree of interaction of vortices in the vertical and radial directions, the pressure loss due to the gas friction against the liquid surface (Balabekov, 2018:184). By processing the experimental data, the expression was obtained to determine :

$$\xi_L = 0,7 \cdot \theta_v \cdot \theta_r \cdot \frac{Re_l^{0,25}}{Re_g^{0,1}}, \quad (8)$$

where Re_l and Re_g – the Reynolds numbers for gas and liquid; θ_v and θ_r – coefficients that take into account the degree of interaction of vortices in the vertical and radial directions.

The Reynolds number for the gas phase, which is determined by the formula:

$$Re_g = \frac{W_g \cdot d_{eq}}{\nu_g} \quad (9)$$

here d_{eq} – the equivalent diameter of the packing, m.

The Reynolds number Re_{*k} is determined by the formula:

$$Re_l = \frac{U_l \cdot d_{eq}}{\nu_l}, \quad (10)$$

where $U_l = L/3600$ – the liquid velocity, m/s.

The overall efficiency of the cyclone-vortex device, taking into account the efficiency of the dry and wet stages, can be calculated by the formula:

$$\eta_{gen} = 1 - (1 - \eta_{ds}) (1 - \eta_{ws}). \quad (11)$$

The dust collection efficiency of a dry stage, based on the centrifugal-inertial model (Shvydkiy, et.al., 2002:640) can be determined by the formula:

$$\eta_{ds} = 1 - \exp[-2(C_{ds} \cdot \psi)^{1/(2n+2)}], \quad (12)$$

where C_{ds} – the coefficient that depends on the design ratios of the device of a dry stage.

For a dry stage, the coefficient C_{ds} is calculated according to the equation (Torskiy et. al., 2019: 6):

$$C_{ds} = \frac{\pi \cdot D_{cp}^2}{a \cdot b_1} \cdot \left[1 - \left(\frac{d}{D_{cp}} \right)^2 \right] \cdot \left(\frac{2 \cdot h_T}{D_{cp}} - \frac{h_v}{D_{cp}} \right) + \left[\left(\frac{d}{D_{cp}} \right)^2 - \left(\frac{d_1}{D_{cp}} \right)^2 \right] \cdot \left(\frac{4 \cdot H_{cp}}{D_{cp}} + \frac{4 \cdot H_{ds}}{D_{cp}} \right) \quad (13)$$

The equation (13) uses the design ratios recommended above.

The quantity in the equation (12) is a modified inertial parameter characterizing the state of the dust-gas mixture (Shvydkiy et. al., 2002: 640):

$$\psi = \frac{d_{ch}^2 \cdot \rho_{ch} \cdot W_{in}}{18 \mu_g \cdot D_{cp}} (n + 1), \quad (14)$$

where W_{in} – the gas velocity at the inlet to the dry stage, m/s.

The quantity n in the equations (12) and (14) according to (Shvydkiy, et.al., 2002:640) is:

$$n = 1 - (1 - 0,0165 \cdot D_{cp}^{0,14}) \cdot \left(\frac{T_g}{283} \right)^{0,3}. \quad (15)$$

Here T_g – the absolute temperature of gases, °K.

The dust collection efficiency of the cyclone-vortex device's packed zone is determined by the formula:

$$\eta_{pzs} = 2,97 \cdot \left(\frac{W_g \cdot d_{ds}}{D_T} \right)^{-1/4}. \quad (16)$$

The turbulent diffusion coefficient is determined by the formula:

$$D_T = B_T \cdot (\xi_L)^{1/3} \cdot (1 - \varepsilon_0)^{1/3} \cdot \left(\frac{H}{t_v} \right)^{1/3} \cdot \left(\frac{\rho_g}{\rho_l} \right)^{1/3} \cdot \left(\frac{1}{h_0} \right)^{1/3} \cdot d_{ds}^{4/3} \cdot u_g \cdot Stk, \quad (17)$$

where $B_T = 8,38 \cdot (1 - \varphi)$ – the correcting coefficient; $Stk = \frac{\rho_{ch} \cdot d_{ch}^2 \cdot u_{ch}}{18 \mu_g \cdot d_{ds}}$ – the Stokes criterion.

The cyclone-vortex action device's design was proposed for the reconstruction of the technological scheme for the purification of gases leaving the boiling bed dryer in chromic sulfate production at Aktobe Plant of Chromic Compounds JSC.

The method for chromic sulphate (basic) production is based on the interaction of sulfur dioxide with a solution of sodium dichromate. Sulfur dioxide is formed when sulfur is burned in a furnace. During the production process, a solution of sodium bichromate with a concentration of (230–300) g/l in terms of CrO_3 enters the reduction column, where the sulfur dioxide gas formed during the combustion of sulfur in the furnace flows in a countercurrent flow, resulting in the formation of a solution of chromic sulfate. The resulting solution of chromic sulfate goes for drying in the “boiling bed” dryer, dried chromic sulfate goes for packaging (Fig 1) (Permanent technological regulations for chromic sulfate production, shop, 2015: 91).

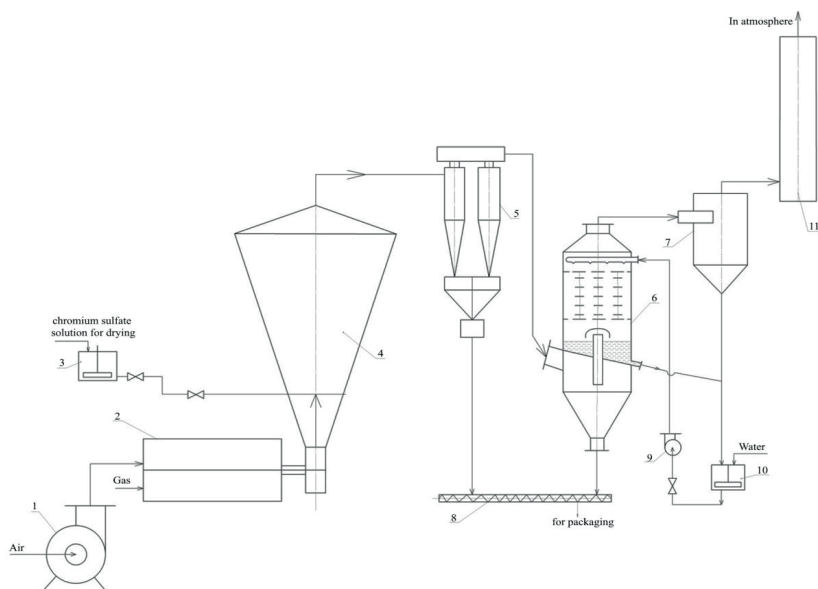

1 – smoke exhauster; 2 – firebox; 3 – boiling bed dryer feeder; 4 – boiling bed dryer; 5 – a group of 6 cyclones; 6 – cyclone-vortex device; 7 – trap; 8 – screw; 9 – pump; 10 – irrigation tank; 11 – sanitary pipe.

Fig 1. The technological scheme for the purification of gases leaving the boiling bed dryer in chromic sulfate production.

From the feeder 3, a syrupy solution of chromic sulfate with a concentration of CrO_3 (380–415) g/l is fed through an atomizer into the “boiling bed” dryer 4. The “boiling bed” dryer is a hollow container with a lattice in the lower part, on which the layer of granular chromic sulfate “cushion” lies. Above the lattice, a disintegrator is installed, which serves to crush the “cushion”. The flue gases obtained by burning natural gas in the firebox 2 enter the lower part of the dryer. As a result of intense heat exchange between the flue gases, the “cushion” and the chromic sulfate solution, the latter is dried. The temperature in the dryer under the lattice is maintained at the level of (145–155)°C due to the dilution of hot gases with cold air. The temperature in the layer is (70–75)°C. The dried chromic sulphate together with the steam-gas mixture with the smoke exhauster D–12 1 is pulled through a group of cyclones 5, where its main part (90–95) % is trapped and collected in the cyclone bunker, from there through the “flashers” and then a system of screws, the dried chromic sulphate enters into the supply hopper of the filling conveyor.

For a more complete purifying (before the reconstruction), the steam-gas mixture passes through a scrubber and the trap 7 irrigated with water, then is thrown out through the sanitary pipe 11 into the atmosphere. Process water is used to irrigate the scrubber. Upon reaching the concentration of (110–120) g/l in terms of CrO_3 , the solution from the irrigation tank of the dryer is pumped into a collection tank, from where it is pumped into the irrigation tank as required.

Air is supplied to the boiling bed dryer by the smoke exhauster 1. Part of the air goes to the atomizer as “primary” for the gas combustion, the rest of the air is supplied directly to the firebox 2 to dilute and cool the flue gases.

During the examination of the existing purification technological scheme, in which the irrigated hollow scrubber was installed as the final stage, the maximum decrease in the dust concentration (average quantity) was $C_{ds} = 0.22 \text{ g/Nm}^3$, which is higher than the standard indicator ($C_{std} = 0.174 \text{ g/Nm}^3$).

In the reconstructed purification scheme, the irrigated scrubber was replaced by the cyclone-vortex device 6.

The diameter of the device was determined from the results of measurements of the velocity field, and the dimensions of the stages were determined according to the recommendations obtained based on the laboratory studies.

The cyclone-vortex device operates as follows.

The gas flow entering the purification is supplied through the nozzle installed tangentially in the lower part of the device. With the tangential supply of the gas flow, a centrifugal force arises, which acts on solid dust particles, pressing them against the inner wall of the device. Under the action of gravity, solid dust particles slide into the conical bottom of the lower contact stage and are removed from the device through the lower fitting.

The dust-free gas flow through the lower cut of the central pipe enters the upper contact stage. At the inlet to it, the central pipe is equipped with a cap to prevent the ingress of flowing irrigation liquid.

The lower and upper stages of contact are separated by an inclined partition, as a result of which they operate autonomously.

The operation of the upper stage of contact occurs in a counter-current mode. In this case, the gas flow entering from below interacts with the irrigation liquid supplied through the irrigator in the packed zone volume. The packed elements' arrangement on the strings is made with the pitch of 2 of the packed body caliber (for plates). This pitch ensures the simultaneous vortex formation mode (in-phase mode) achievement. The simultaneous vortex formation mode is characterized by the coincidence of the time of vortex formation behind the packed bodies and the time of motion of the formed vortices behind the chain of packed bodies located in the gas flow direction. At the moment of approach, there is an interaction of the vortices that have flown in and have completed the cycle of vortex formation behind the packed bodies. As a result of this interaction, the total power of the vortices increases, which makes it possible to do a lot of work on crushing the irrigation liquid and creating a highly developed surface.

The purified gas flow is removed from the device through the outlet fitting. The spent liquid in the upper stage is removed from the device through the fitting.

During the tests of the reconstructed technological scheme, carried out jointly with the enterprise employees, the following research results were obtained. The ranges of changes in the main gas flow parameters during the passage of gas cleaning equipment:

- Up to a group of cyclones
- gas temperature 61–65°C;

- pressure (350–460) Pa;
- gas consumption 6780–7760 Nm³/h;
- average dust concentration 8.0 g/Nm³.

After a group of cyclones

- gas temperature 58–63°C;
- pressure (480–510) Pa;
- gas consumption 8100–8770 Nm³/h;
- average dust concentration 2.405 g/Nm³.

After the cyclone-vortex device

- gas temperature 43–52°C;
- pressure (160–200) Pa;
- gas consumption 10630–11770 Nm³/h;
- average dust concentration 0.029 g/Nm³.

Figure 2 shows graphical dependences of the hydraulic resistance and the dust collection efficiency of the cyclone-vortex device obtained as a result of industrial tests and the calculated quantities according to the equations (1) and (11).

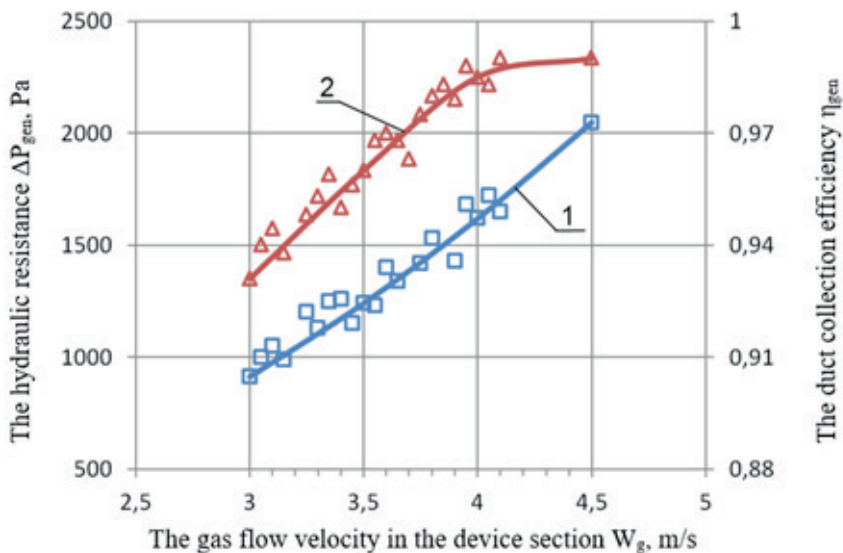

Experimental conditions: irrigation density $L = 25 \text{ m}^3/\text{m}^2\text{h}$; the vertical pitch between the plate packed elements $t_v = 2b$, in the radial direction $t_r = 2b$; the size of the plates $b \times b \times \delta = 50 \times 50 \times 1 \text{ mm}$; the average diameter of the trapped particles $d_{cht} = 5 \text{ microns}$.

The curves – calculation; the points – experimental data

1 – ΔP_{gen} ; 2 – η_{gen} .

Fig 2. Dependence of the hydraulic resistance and the dust collection efficiency of the cyclone-vortex device on the gas flow velocity in the section of the device.

As can be seen from the figure, the hydraulic resistance and the dust collection efficiency of the cyclone-vortex device increase in the entire range of gas velocities.

Discussion

The hydraulic resistance of the device consists of the resistances of the cyclone and packed parts. In the cyclone part, an increase in the hydraulic resistance with an increase in the gas velocity is due to an increase in the dynamic head and losses associated with a change in the direction of gas motion and friction losses. The results of laboratory studies of the hydraulic resistance of the packed zone indicate that in the velocity range from 2.5 to 4 m/s a drop mode occurs, in which the liquid phase is mainly presented in the form of drops. The operation of the device achieves the highest stabilization at 4.0 m/s. The uniformity of the distribution of flows over the cross-section of the device improves, the turbulence of the gas-liquid flow increases due to the intensification of the process of formation and separation of vortices behind the streamlined bodies.

The dust collection efficiency in the device consists of the efficiency of the cyclone and packed parts.

In cyclone-type devices, the most effective force acting on suspended solids is the centrifugal force, the quantity of which is largely determined by the gas flow velocity. With an increase in the gas consumption, and, consequently, its velocity, the centrifugal force increases, and the efficiency of collecting particles increases.

The dust collection efficiency of the packed zone in the drop mode achieves its maximum quantities, after which a further increase in the gas velocity leads to the entrainment of liquid from the device and the efficiency of the process is somewhat reduced. High quantities of the degree of dust collection are due to the vortex crushing of liquid in the packed zone of the device. Since the vortex separation frequency from the packed elements and, accordingly, the intensity and frequency of pulsations increase in proportion to the gas velocity, with unchanged packed parameters, this leads to an intensification of the process of the liquid film separation and its subsequent crushing into smaller drops. This naturally increases the contact surface of the phases, and, ultimately, the dust collection efficiency.

The tests carried out confirmed the possibility of effective dust collection from gas emissions in the cyclone-vortex device.

The cyclone-vortex device was implemented in the technological scheme for the purification of gases leaving the boiling bed dryer in chromic sulfate production at Aktobe Plant of Chromic Compounds JSC.

Conclusions

Based on recommendations for the manufacture of cyclones, as well as the research results and recommendations for the design of devices with a regular movable packing, with shock-vortex interaction of flows, the design ratios of the cyclone and packed stages of the cyclone-vortex action device were established.

Based on the results of laboratory studies, the main calculated dependences of the hydraulic resistance and dust collection parameters of the cyclone and packed stages and the device as a whole were obtained.

The cyclone-vortex action device's design was proposed for the reconstruction of the technological scheme for the purification of gases leaving the boiling bed dryer in chromic sulfate production at Aktobe Plant of Chromic Compounds JSC.

Based on the results of industrial tests, the graphical dependences of the hydraulic resistance and the dust collection efficiency of the cyclone-vortex device on the gas flow velocity in the cross-section of the device were obtained and the analysis was carried out. It was noted that in the cyclone part, an increase in the hydraulic resistance with an increase in the gas velocity is due to an increase in the dynamic head and losses associated with a change in the direction of gas motion and friction losses. The effective force acting on suspended solids is the centrifugal force, the quantity of which is largely determined by the gas flow velocity. In the packed zone, the operation of the device proceeds in the drop mode, characterized by the uniformity of the distribution of flows over the cross-section of the device, an increase in the turbulence of the gas-liquid flow, the intensity and increase in the frequency of pulsations. This contributes to an increase in the dust collection efficiency.

The cyclone-vortex device was implemented in the technological scheme for the purification of gases leaving the boiling bed dryer in chromic sulfate production at Aktobe Plant of Chromic Compounds JSC.

As recommendations for improving the proposed device design, it can be noted that to purify high-temperature multicomponent gases, it is necessary to use a regular structure tubular packing as a packing.

REFERENCES

- Balabekov O.S., Volnenko A.A. (2018). Calculation and design of heat and mass transfer and dust collecting devices with a movable and regular packing. Shymkent: M.O. Auezov South Kazakhstan State University. — 2018.
- Gordon G.M., Peisakhov I.L. (1977). Dust collection and gas cleaning in non-ferrous metallurgy. Moscow: Metallurgy. — 1977.
- Issayeva A., Korganbayev B., Volnenko A. & Zhumadullayev D. (2021). Study of the influence of operating conditions on the hydrodynamic regularities of a regular tubular packing. Reports of the NAS RK. —2021. — Vol. 5(339), — Pp. 151–157. — doi: 10.32014/2021.2518–1483.94.
- Khussanov Zh.Ye. (2011). Development and calculation of complex gas cleaning processes in a combined gas-liquid apparatus with autonomous irrigation circuits. Shymkent: SKSU. — 2011.
- Permanent technological regulations for chromic sulfate production, shop (2015). Aktobe: Aktobe Plant of Chromic Compounds JSC. — 2011.
- Ramatullayeva L.I. (2009). Hydrodynamics and trapping aerosols in an apparatus with shock-vortex interaction of flows. Shymkent: SKSU. — 2009.
- Rusakov A.A., Yankovskiy S.S. (1970). Dispersion impactors for industrial dust analysis. Moscow: TSNIITEN ftekhim. — 1970.
- Shvydkiy V.S., Ladygichev M.G. (2002). Gas purification: Reference book. Moscow: Teploenergetik. — 2002.
- Strauss W. (1974). Industrial gas cleaning. Oxford: Pergamon Press. — 1974.
- Tarat E.Ya., Vorobyev O.G., Balabekov O.S. (1979). Purification of gases in the production of phosphorus and phosphorus fertilizers. Leningrad: Chemistry. — 1979.
- Torskiy A.O., Volnenko A.A., Abzhapbarov A.A., Levanskiy A.E. (2018). Hydrodynamics of a swirling flow in the cyclone-vortex apparatus. News of the academy of sciences of the republic of Kazakhstan. Series chemistry and technology. —2018. — Vol. 2(428), — Pp.72–79.
- Torskiy A.O., Volnenko A.A., Orynbekov T., Abzhapbarov A.A., Levanskiy A.E. (2019) Methodology for calculating hydraulic resistance and dedusting efficiency of a cyclonic-vortex apparatus. Proceedings of VI International Conference “Industrial Technologies and Engineering” (ICITE 2019). — 2019. — Vol. 2, — Pp. 75–80.

Vetoshkin A.G. (2005). Dust cleaning processes and devices. Penza: Publishing house of Penza State University. — 2005.

Volnenko A.A., Balabekov O.S. (2018) Calculation of heat-mass-exchange and dust collecting apparatus with a weighted and regular nozzle. Examples and tasks. Shymkent: M.O. Auezov South Kazakhstan State University. — 2018.

Zhumadullayev D.K., Torskiy A.O., Volnenko A.A., Abzhapbarov A.A., Korganbayev B.N. (2020) Calculation of hydrodynamic characteristics of a cyclonic-vortex apparatus. International Journal of Emerging Trends in Engineering Research. — 2020. — Vol. 8(9), — Pp. 6091–6097.

CONTENT

G.Yu. Abdugaliyeva, G.K. Daumova, B.E. Makhiyev, A. Akylkankyzy PROGNOSIS OF INJURIES AT METALLURGICAL PLANTS OF KAZZINC LLP BY MATHEMATICAL MODELING.....	8
B. Assanova, B. Orazbayev, Zh. Moldasheva, V. Makhatova, R. Tuleuova A FUZZY DECISION-MAKING METHOD FOR CONTROLLING OPERATION MODES OF A HARD-TO-FORMALISE RECTIFICATION COLUMN OF A DELAYED COKING UNIT.....	17
K.A. Battakova, A.A. Saipov GEOGRAPHICAL ASPECTS OF THE IMPACT OF TECHNOGENESIS ON THE ACCUMULATION OF HEAVY METALS IN SOILS AND POLLUTION OF SURFACE WATERS OF CENTRAL KAZAKHSTAN.....	31
M. Begentayev, M. Nurpeisova, E. Kuldiev, R. Nurlybaev, U. Bek STUDY OF THE INFLUENCE OF TECHNOLOGICAL FACTORS ON THE DENSITY AND STRENGTH OF ASH-GAS CONCRETE.....	45
A.A. Bokanova, A.A. Abdurrahmanov, B.K. Kurpenov, A.I. Kamardin, T.D. Imanbekova DEVELOPMENT OF A CORONA DISCHARGE GAS ANALYZER FOR AIR DISINFECTION.....	58
G.Zh. Bulekbayeva, O.G. Kikvidze, A.U. Tabylov, A.Z. Bukayeva, N.B. Suyeuova APPLICATION OF THE COMBINED FINISHING AND HARDENING METHOD FOR COMPLEX QUALITY PARAMETERS OF THE PARTS SURFACE LAYER.....	68
A.A. Volnenko, A.E. Leudanski, A.S. Serikov, A.N. Issayeva, D.K. Zhumadullayev CALCULATION AND IMPLEMENTATION OF A CYCLONE-VORTEX DEVICE IN CHROMIC SULPHATE PRODUCTION.....	80
N. Zhalgasuly, A.A. Ismailova, U.A. Bektibayev, T.Zh. Zhumagulov PURIFICATION OF PRODUCED WATER AFTER MINING.....	95
L. Zhiyenkulova, M. Yessenamanova, M. Jexenov, E.G. Koroleva, F. Nurbayeva ECOLOGICAL AND LIMNOLOGICAL RESEARCH OF THE SUSTAINABILITY OF THE ECOSYSTEM OF THE LAKE INDER.....	111
L.Z. Issayeva, Z.N. Ablessenova, K.S. Togizov, S.K. Assubayeva, L.V. Petrova HYDROTHERMALLY ALTERED ROCKS OF THE AKMAYA-QATPAR ORE ZONE AND THEIR REFLECTION IN GEOPHYSICAL FIELDS.....	128
Zh. Kadasheva, B. Mukhambetov, R. Abdinov, Ye. Kabiyeu, R. Meranzova STUDYING DWARFISM IN <i>KOCHIA PROSTRATA</i> GROWTH ON SALINE LANDS OF THE NORTHERN CASPIAN DESERT.....	143
B.Z. Kaliyev, B.K. Mauletbekova, T.D. Karmanov, B.A. Zhautikov, Zh.K. Tatayeva TECHNIQUE AND TECHNOLOGICAL FEATURES OF SEPARATION OF SPENT DRILLING FLUIDS INTO LIQUID AND SOLID PHASES FOR THE PURPOSE OF REUSE OF SEPARATION PRODUCTS.....	155

I.B. Kozhabaeva, A.A.Yerzhan, P.V. Boikachev, Z.D. Manbetova, A.K. Issataeva DEVELOPMENT OF A DIRECTION FINDER WITH DIRECTION DETERMINATION FOR SMALL-SIZED UNMANNED AERIAL VEHICLES.....	164
G. Madimarova, T. Nurpeissova, D. Kairatov, D. Suleimenova, Sh. Zhantyeva INSPECTION AND CARRYING OUT GNSS MONITORING OF POINTS OF THE STATE GEODETIC NETWORK IN THE TERRITORY OF KAZAKHSTAN.....	179
A.P. Permana, A. Suaib, R. Hutagalung, S.S. Eraku ANALYSIS OF THE RELATIVE AGE OF LIMESTONE AT TANJUNG KRAMAT REGION, GORONTALO CITY, INDONESIA.....	190
O.S. Reshetnikova, K.B. Kyzyrov, V.V. Yurchenko STRUCTURAL SYNTHESIS OF HYDRAULIC IMPACT MECHANISMS WITH A COMBINED CONTROL BODY.....	201
D. Ryskalieva, S. Syrlybekkyzy, S. Sagyndykova, A. Mustafina, G. Saparova DEPENDENCE OF MOBILE SULFUR ACCUMULATION IN SOILS AND HYDROGEN SULFIDE EMISSIONS ON THE TERRITORY OF ATYRAU.....	218
K.T. Saparov, Zh.R. Shakhantayeva, A.Ye. Yeginbayeva, N.Y. Yessenkeldiyev, J.A. Wendt THE SYSTEM OF TOPONYMS CHARACTERIZING THE GEOLOGICAL STRUCTURE AND MINERALS OF THE ZHAMBYL REGION.....	238
A. Togasheva, R. Bayamirova, M. Sarbopeyeva, M. Bisengaliev, V.L. Khomenko MEASURES TO PREVENT AND COMBAT COMPLICATIONS IN THE OPERATION OF HIGH-VISCOSITY OILS OF WESTERN KAZAKHSTAN.....	257
J.B. Toshov, K.T. Sherov, M.R. Sikhimbayev, B.N. Absadykov, A. Esirkepov ANALYSIS OF INTERACTION OF ROCK BREAKING TOOL WITH ROCK IN THE DRILLING PROCESS.....	271

Publication Ethics and Publication Malpractice in the journals of the National Academy of Sciences of the Republic of Kazakhstan

For information on Ethics in publishing and Ethical guidelines for journal publication see <http://www.elsevier.com/publishingethics> and <http://www.elsevier.com/journal-authors/ethics>.

Submission of an article to the National Academy of Sciences of the Republic of Kazakhstan implies that the described work has not been published previously (except in the form of an abstract or as part of a published lecture or academic thesis or as an electronic preprint, see <http://www.elsevier.com/postingpolicy>), that it is not under consideration for publication elsewhere, that its publication is approved by all authors and tacitly or explicitly by the responsible authorities where the work was carried out, and that, if accepted, it will not be published elsewhere in the same form, in English or in any other language, including electronically without the written consent of the copyright-holder. In particular, translations into English of papers already published in another language are not accepted.

No other forms of scientific misconduct are allowed, such as plagiarism, falsification, fraudulent data, incorrect interpretation of other works, incorrect citations, etc. The National Academy of Sciences of the Republic of Kazakhstan follows the Code of Conduct of the Committee on Publication Ethics (COPE), and follows the COPE Flowcharts for Resolving Cases of Suspected Misconduct (http://publicationethics.org/files/u2/New_Code.pdf). To verify originality, your article may be checked by the Cross Check originality detection service <http://www.elsevier.com/editors/plagdetect>.

The authors are obliged to participate in peer review process and be ready to provide corrections, clarifications, retractions and apologies when needed. All authors of a paper should have significantly contributed to the research.

The reviewers should provide objective judgments and should point out relevant published works which are not yet cited. Reviewed articles should be treated confidentially. The reviewers will be chosen in such a way that there is no conflict of interests with respect to the research, the authors and/or the research funders.

The editors have complete responsibility and authority to reject or accept a paper, and they will only accept a paper when reasonably certain. They will preserve anonymity of reviewers and promote publication of corrections, clarifications, retractions and apologies when needed. The acceptance of a paper automatically implies the copyright transfer to the National Academy of Sciences of the Republic of Kazakhstan.

The Editorial Board of the National Academy of Sciences of the Republic of Kazakhstan will monitor and safeguard publishing ethics.

Правила оформления статьи для публикации в журнале смотреть на сайте:

[www:nauka-nanrk.kz](http://www.nauka-nanrk.kz)

<http://www.geolog-technical.kz/index.php/en/>

ISSN 2518-170X (Online),

ISSN 2224-5278 (Print)

Подписано в печать 15.02.2024.

Формат 70x90^{1/16}. Бумага офсетная. Печать – ризограф.
18,0 п.л. Тираж 300. Заказ 1.