

ISSN 2518-170X (Online),
ISSN 2224-5278 (Print)

ҚАЗАҚСТАН РЕСПУБЛИКАСЫ
ҰЛТТЫҚ ҒЫЛЫМ АКАДЕМИЯСЫНЫҢ
Satbayev University

Х А Б А Р Л А Р Ы

ИЗВЕСТИЯ

НАЦИОНАЛЬНОЙ АКАДЕМИИ НАУК
РЕСПУБЛИКИ КАЗАХСТАН
Satbayev University

NEWS

OF THE ACADEMY OF SCIENCES
OF THE REPUBLIC OF KAZAKHSTAN
Satbayev University

**SERIES
OF GEOLOGY AND TECHNICAL SCIENCES**

1 (445)

JANUARY – FEBRUARY 2021

THE JOURNAL WAS FOUNDED IN 1940

PUBLISHED 6 TIMES A YEAR

ALMATY, NAS RK

NAS RK is pleased to announce that News of NAS RK. Series of geology and technical sciences scientific journal has been accepted for indexing in the Emerging Sources Citation Index, a new edition of Web of Science. Content in this index is under consideration by Clarivate Analytics to be accepted in the Science Citation Index Expanded, the Social Sciences Citation Index, and the Arts & Humanities Citation Index. The quality and depth of content Web of Science offers to researchers, authors, publishers, and institutions sets it apart from other research databases. The inclusion of News of NAS RK. Series of geology and technical sciences in the Emerging Sources Citation Index demonstrates our dedication to providing the most relevant and influential content of geology and engineering sciences to our community.

Қазақстан Республикасы Ұлттық ғылым академиясы "ҚР ҰҒА Хабарлары. Геология және техникалық ғылымдар сериясы" ғылыми журналының Web of Science-тің жаңаланған нұсқасы Emerging Sources Citation Index-те индекстелуге қабылданғанын хабарлайды. Бұл индекстелу барысында Clarivate Analytics компаниясы журналды одан әрі the Science Citation Index Expanded, the Social Sciences Citation Index және the Arts & Humanities Citation Index-ке қабылдау мәселесін қарастыруда. Web of Science зерттеушілер, авторлар, баспашылар мен мекемелерге контент тереңдігі мен сапасын ұсынады. ҚР ҰҒА Хабарлары. Геология және техникалық ғылымдар сериясы Emerging Sources Citation Index-ке енуі біздің қоғамдастық үшін ең өзекті және беделді геология және техникалық ғылымдар бойынша контентке адалдығымызды білдіреді.

НАН РК сообщает, что научный журнал «Известия НАН РК. Серия геологии и технических наук» был принят для индексирования в Emerging Sources Citation Index, обновленной версии Web of Science. Содержание в этом индексировании находится в стадии рассмотрения компанией Clarivate Analytics для дальнейшего принятия журнала в the Science Citation Index Expanded, the Social Sciences Citation Index и the Arts & Humanities Citation Index. Web of Science предлагает качество и глубину контента для исследователей, авторов, издателей и учреждений. Включение Известия НАН РК. Серия геологии и технических наук в Emerging Sources Citation Index демонстрирует нашу приверженность к наиболее актуальному и влиятельному контенту по геологии и техническим наукам для нашего сообщества.

Б а с р е д а к т о р ы
э. ғ. д., профессор, ҚР ҰҒА академигі

И.К. Бейсембетов

Бас редакторының орынбасары
Жолтаев Г.Ж. проф., геол.-мин. ғ. докторы

Р е д а к ц и я а л қ а с ы:

Абаканов Т.Д. проф. (Қазақстан)
Абишева З.С. проф., академик (Қазақстан)
Абсадыков Б.Н. проф., корр.-мүшесі (Қазақстан)
Агабеков В.Е. академик (Беларусь)
Алиев Т. проф., академик (Әзірбайжан)
Бакиров А.Б. проф., (Қырғызстан)
Буктуков Н.С. проф., академик (Қазақстан)
Булат А.Ф. проф., академик (Украина)
Ганиев И.Н. проф., академик (Тәжікстан)
Грэвис Р.М. проф. (АҚШ)
Жарменов А.А. проф., академик (Қазақстан)
Конторович А.Э. проф., академик (Ресей)
Курскеев А.К. проф., академик (Қазақстан)
Курчавов А.М. проф., (Ресей)
Медеу А.Р. проф., академик (Қазақстан)
Оздоев С.М. проф., академик (Қазақстан)
Постолатий В. проф., академик (Молдова)
Степанец В.Г. проф., (Германия)
Штейнер М. проф. (Германия)

«ҚР ҰҒА Хабарлары. Геология және техникалық ғылымдар сериясы».

ISSN 2518-170X (Online),
ISSN 2224-5278 (Print)

Меншіктенуші: «Қазақстан Республикасының Ұлттық ғылым академиясы» РҚБ (Алматы қ.).

Қазақстан Республикасының Ақпарат және қоғамдық даму министрлігінің Ақпарат комитетінде
29.07.2020 ж. берілген № **KZ39VPY00025420** мерзімдік басылым тіркеуіне қойылу туралы куәлік.

Тақырыптық бағыты: геология және техникалық ғылымдар бойынша мақалалар жариялау.

Мерзімділігі: жылына 6 рет.
Тиражы: 300 дана.

Редакцияның мекенжайы: 050010, Алматы қ., Шевченко көш., 28, 219, 220 бөл.,
тел.: 272-13-19, 272-13-18,

<http://www.geolog-technical.kz/index.php/en/>

© Қазақстан Республикасының Ұлттық ғылым академиясы, 2021

Типографияның мекенжайы: «NurNaz GRACE», Алматы қ., Рысқұлов көш., 103.

Главный редактор
д. э. н., профессор, академик НАН РК

И. К. Бейсембетов

Заместитель главного редактора
Жолтаев Г.Ж. проф., доктор геол.-мин. наук

Редакционная коллегия:

Абаканов Т.Д. проф. (Казахстан)
Абишева З.С. проф., академик (Казахстан)
Абсадыков Б.Н. проф., чл.-корр. (Казахстан)
Агабеков В.Е. академик (Беларусь)
Алиев Т. проф., академик (Азербайджан)
Бакиров А.Б. проф., (Кыргызстан)
Буктуков Н.С. проф., академик (Казахстан)
Булат А.Ф. проф., академик (Украина)
Ганиев И.Н. проф., академик (Таджикистан)
Грэвис Р.М. проф. (США)
Жарменов А.А. проф., академик (Казахстан)
Конторович А.Э. проф., академик (Россия)
Курскеев А.К. проф., академик (Казахстан)
Курчавов А.М. проф., (Россия)
Медеу А.Р. проф., академик (Казахстан)
Оздоев С.М. проф., академик (Казахстан)
Постолатий В. проф., академик (Молдова)
Степанец В.Г. проф., (Германия)
Штейнер М. проф. (Германия)

«Известия НАН РК. Серия геологии и технических наук».

ISSN 2518-170X (Online),
ISSN 2224-5278 (Print)

Собственник: Республиканское общественное объединение «Национальная академия наук Республики Казахстан (г. Алматы).

Свидетельство о постановке на учет периодического печатного издания в Комитете информации Министерства информации и общественного развития Республики Казахстан № **KZ39VPY00025420**, выданное 29.07.2020 г.

Тематическая направленность: публикация статей по геологии и технических наукам.

Периодичность: 6 раз в год.

Тираж: 300 экземпляров.

Адрес редакции: 050010, г. Алматы, ул. Шевченко, 28, ком. 219, 220, тел.: 272-13-19, 272-13-18,
<http://www.geolog-technical.kz/index.php/en/>

© Национальная академия наук Республики Казахстан, 2021

Адрес типографии: «NurNaz GRACE», г. Алматы, ул. Рыскулова, 103.

E d i t o r i n c h i e f

doctor of Economics, professor, academician of NAS RK

I. K. Beisembetov

Deputy editor in chief

Zholtayev G.Zh. prof., dr. geol-min. sc.

E d i t o r i a l b o a r d:

Abakanov T.D. prof. (Kazakhstan)
Abisheva Z.S. prof., academician (Kazakhstan)
Absadykov B.N. prof., corr. member. (Kazakhstan)
Agabekov V.Ye. academician (Belarus)
Aliyev T. prof., academician (Azerbaijan)
Bakirov A.B. prof., (Kyrgyzstan)
Buktukov N.S. prof., academician (Kazakhstan)
Bulat A.F. prof., academician (Ukraine)
Ganiyev I.N. prof., academician (Tadjikistan)
Gravis R.M. prof. (USA)
Zharmenov A.A. prof., academician (Kazakhstan)
Kontorovich A.Ye. prof., academician (Russia)
Kurskeyev A.K. prof., academician (Kazakhstan)
Kurchavov A.M. prof., (Russia)
Medeu A.R. prof., academician (Kazakhstan)
Ozdoyev S.M. prof., academician (Kazakhstan)
Postolatii V. prof., academician (Moldova)
Stepanets V.G. prof., (Germany)
Steiner M. prof. (Germany)

News of the National Academy of Sciences of the Republic of Kazakhstan. Series of geology and technology sciences.

**ISSN 2518-170X (Online),
ISSN 2224-5278 (Print)**

Owner: RPA "National Academy of Sciences of the Republic of Kazakhstan" (Almaty).

The certificate of registration of a periodical printed publication in the Committee of information of the Ministry of Information and Social Development of the Republic of Kazakhstan **No. KZ39VPY00025420**, issued 29.07.2020.

Thematic scope: *publication of papers on geology and technical sciences.*

Periodicity: 6 times a year.

Circulation: 300 copies.

Editorial address: 28, Shevchenko str., of. 219, 220, Almaty, 050010, tel. 272-13-19, 272-13-18,
<http://www.geolog-technical.kz/index.php/en/>

© National Academy of Sciences of the Republic of Kazakhstan, 2021

Address of printing house: «NurNaz GRACE», 103, Ryskulov str, Almaty.

NEWS

OF THE NATIONAL ACADEMY OF SCIENCES OF THE REPUBLIC OF KAZAKHSTAN

SERIES OF GEOLOGY AND TECHNICAL SCIENCES

ISSN 2224-5278

Volume 1, Number 445 (2021), 39 – 45

<https://doi.org/10.32014/2021.2518-170X.6>

UDC 621.391.837:621.397.13

M. Amreev¹, R. Safin², T. Pavlova¹, E. Temyrkanova¹, Y. Garmashova¹¹Almaty University of Power Engineering and Telecommunication, Almaty, Kazakhstan;²Kazakh University Ways of Communications, Almaty, Kazakhstan.

E-mail: max.amreev@gmail.com

**AMPLIFIER DESIGN FOR MODELING THE TRANSMISSION
OF A DIGITAL VIDEO SIGNAL OVER
A DATA TRANSMISSION CHANNEL**

Abstract. The use of video surveillance systems is used in the areas of security, law and order, in the territories of protected objects, in monitoring the movement of road vehicles and in other areas.

The main disadvantage of a video surveillance system is its susceptibility to weather influences (rain, fog, snowfall, etc.), which degrades the quality of the video system by reducing the signal level.

Therefore, the urgency of finding new ways and possibilities to improve the quality of video signals is one of the priority areas of signal processing. The main task of this work was to determine the main parameters, simulate the transmission line and amplifier, and select the schematic diagram of the transmitting and receiving path with the voltage and current ratings.

Both the receiver and the cable video transmitter have different means of adjusting to different transmission line lengths. The signal at the output of each receiver should be in the range from 0.9 to 1.1 V, and the spread of the total ohmic resistance of the wires of the video transmission line at the input of the receiver should be no more than 2 – 3%. Based on these parameters, the equipment is configured for transmitting video over the channel. The magnitude of the mismatch is regulated by potentiometers, which allow smooth adjustment of the video transmission equipment [1].

As a rule, video transmission over the channel is carried out at a distance of 50 to 1500 m. If it is necessary to transmit video at distances less than 50 m, additional resistances are connected in series at the receiver input so that the total line resistance is 30 - 50 Ohm [1].

Key words: data transmission channel, video surveillance, television signal, operational amplifier.

Video surveillance systems are used in the sphere of law enforcement, on the territories of protected facilities, for monitoring the movement of vehicles and in other areas.

The main disadvantage of a video surveillance system is its vulnerability to weather conditions (rain, fog, snowfall, etc.), which degrades the quality of the video system by reducing the signal level.

Therefore, the urgency for finding new ways and possibilities of improving the quality of video signals is one of the priority directions of signal processing. The main task of this article is to determine the main parameters, to model the transmission line and amplifier, and to select a basic circuit of the receiving and transmitting path with voltage and current ratings.

Both video cable transmitter and receiver have different settings for various transmission line lengths. The signal at the output of each receiver should be in the range from 0.9 to 1.1 V, and the value deviations of the total ohmic impedance on the video transmission line cables at the receiver input should not exceed 2 – 3 %. Based on these parameters, the equipment is configured to transmit video over the channel. The magnitude of the mismatch is regulated by a potentiometer that allows performing a smooth hardware configuration of the video transmission [1].

As a rule, video transmission over the channel is carried between 50 and 1500 m. If it is necessary to transmit video over distances less than 50 m, additional impedances are sequentially turned on at the receiver input so that the total line impedance becomes 30 – 50 Ohms [1].

The stray capacitance of the line is compensated by special jumpers in the receiver. The level of compensation for the stray capacitance of the video transmission line is selected individually for each transmission line based on the video picture on the test monitor. Also, using a test monitor or an oscilloscope, the receiver is configured according to the amplitude of the output signal.

Using a multi-channel video receiver to improve the parameters of the received signal, it is sometimes advisable to connect monitors to the receiver outputs via an impedance series of 51- 82 Ohms.

In addition to interference from radio apparatus and power lines, sometimes the video transmission line is affected by electromagnetic interference received as a result of a lightning discharge. Such interferences can be quite strong, as a result of which the equipment for transmitting video through a twisted pair will fail. To avoid damage, it is necessary to use lightning protection on the video channel transmission lines.

Figure 1 shows a typical circuit for switching on a differential amplifier. It can be used as a video signal booster. In this circuit, the amplification factor is calculated using the formula:

$$K = \frac{V_{OUT}}{V_{IN}} = \frac{R_F}{R_G},$$

where V_{OUT} is the output voltage, V; V_{IN} – input voltage, V; R_F – feedback impedance, Ohm; R_G – input impedance of the circuit, Ohm.

Resistors R_0 help keep the amplifier in a stable state. It is recommended to select resistors with at least a nominal accuracy of no more than 0.1 %.

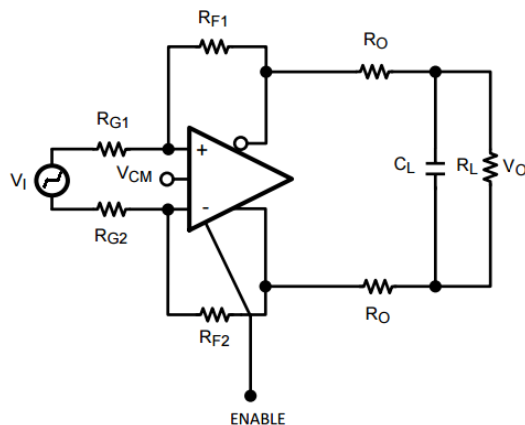

Figure 1 – A typical circuit of the amplifier switching

A high-speed broadband amplifier is the main component for transmitting a video signal over a data transmission channel. As a digital signal amplifier, the MAX403 OP-amp from the “Maxim Integrated Products, Inc” was selected, which was chosen as the most suitable for all requirements after careful analysis with analogues of this type of OP-amp.

Modeling the amplifier and transmission line.

The simulation results in OrCAD 9.1 for resistor impedances and long line values on a twisted pair are shown in figure 2.

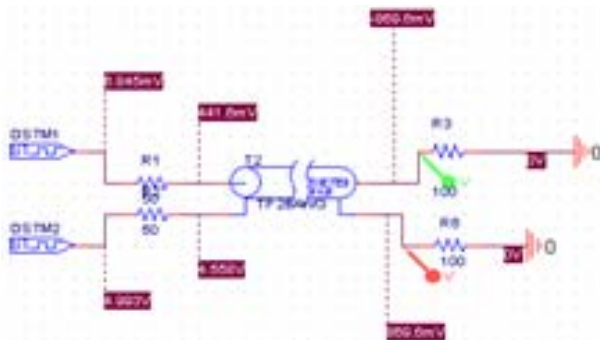

Figure 2 – Transmission line modeling

With a line length of 100 meters, figure 3 clearly shows signal delays of 0.62 μ s. The signal is clear, its amplitude is about 1.5 V.

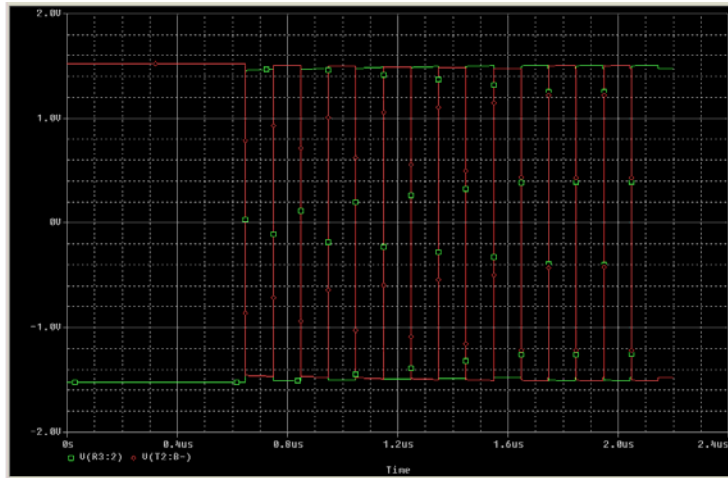

Figure 3 – Diagrams of antiphase signals U(R3; 2) and U(T2; B-) at the output of a long line of 100 meters on the same scale

There is the second signal in the opposite phase after the amplifier, which is clearly visible on the oscillogram. Figure 4 shows the signals transmitted through a 200-meter line.

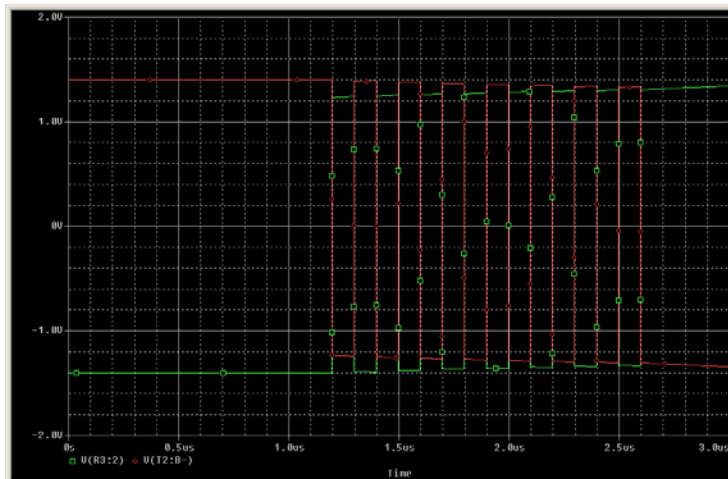

Figure 4 – Diagrams of antiphase signals U(R3; 2) and U(T2; B-) at the output of a long line of 200 meters on the same scale

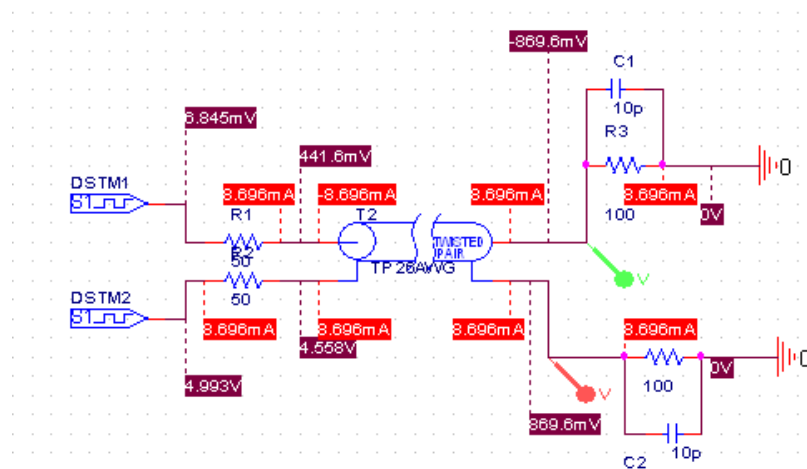

Figure 5 – Voltage and current ratings of circuit components

On a 200-meter line, we would like to note that the signal delay had increased to 1.2 μ s. The signal amplitude had decreased to 1.4 V. Each pulse is distinct, but it is noticeably declining.

Figure 6 shows peaks in the signals U (R₃; 2) and U (T₂; B-), which occur when a 10 pF capacitors are inserted to load the circuit. Small bursts (peaks) are noticeable at 0.75, 1.85, and 2.05 μ s for the U (R₃; 2) signal and for the U (T₂; B-) signal at 0.75, 0.8, 1.75, 1.95, and 2.15 μ s.

Similar measurements were also made for lines from 300 to 1000 meters with 100 m increments.

After receiving the simulation measurement data, the following results were obtained at a speed of 10 Mbit/s and a speed of 100 Mbit/s; it is summarized in tables 1 and 2.

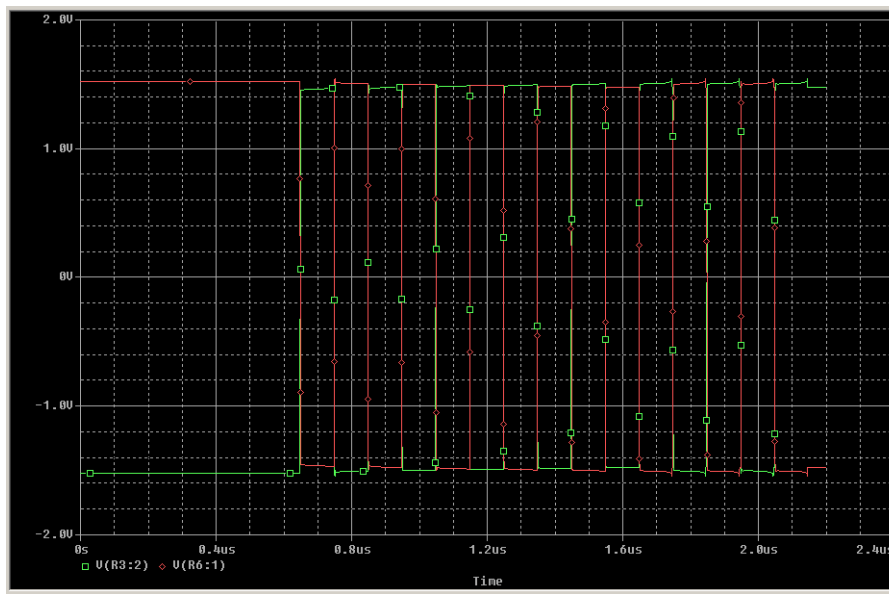

Figure 6 – Diagrams of antiphase signals U(R₃; 2) and U(T₂; B-) at the output of a long line of 100 meters with capacitive parameters on the same scale

Table 1 – Video signal transmission performance at 10 Mbit/s

Characteristics	Measurement data									
Line length, m	100	200	300	400	500	600	700	800	900	1000
Signal amplitude, V	1,5	1,3	1,2	1	0,9	0,8	0,7	1,2	1,1	1
Signal delay, μ s	0,65	1,2	1,75	2,3	2,85	3,4	3,95	4,5	5,2	5,59

Table 2 – Video signal transmission performance at 100 Mbit/s

Characteristics	Measurement data		
Line length, m	100	500	1000
Signal amplitude, V	1,5	0,9	1
Signal delay, μ s	559	2750	5490

Devices that use fully differential amplifiers have certain specifications. The main requirements are high linearity and the necessary signal amplitude. Linearity is achieved by using a well-chosen feedback line and setting the amplification factor by means of resistors, as well as appropriate supply voltage. The signal amplitude can be adapted using the appropriate amplification factors. The MAX403 operational amplifier, which was selected for the simulation, requires the installation of bypass capacitors of 0.01 and 0.1 μ F. All capacitors must be grounded. Sinusoidal noise output can lead to loss of dynamic range and

increased distortion. In addition, capacitive loads must be isolated from the amplifier output by small-value resistors. This is particularly true when the load has a resistive component that exceeds 500 Ohms. A typical A/D converter has a capacitive element of about 10 pF, and the component can be resistive for over 1000 Ohms. During transmission over a data channel, such as a coaxial one, the resistive component will be 50 Ohms; over a twisted pair it will be 100 Ohms. The usage of appropriate resistors will be sufficient to isolate any subsequent capacitance [5]. The supply voltage is set to +12 V and -12 V, the general output mode is 0 V [4]. The basic circuit of the receiving and transmitting path is shown in figure 7.

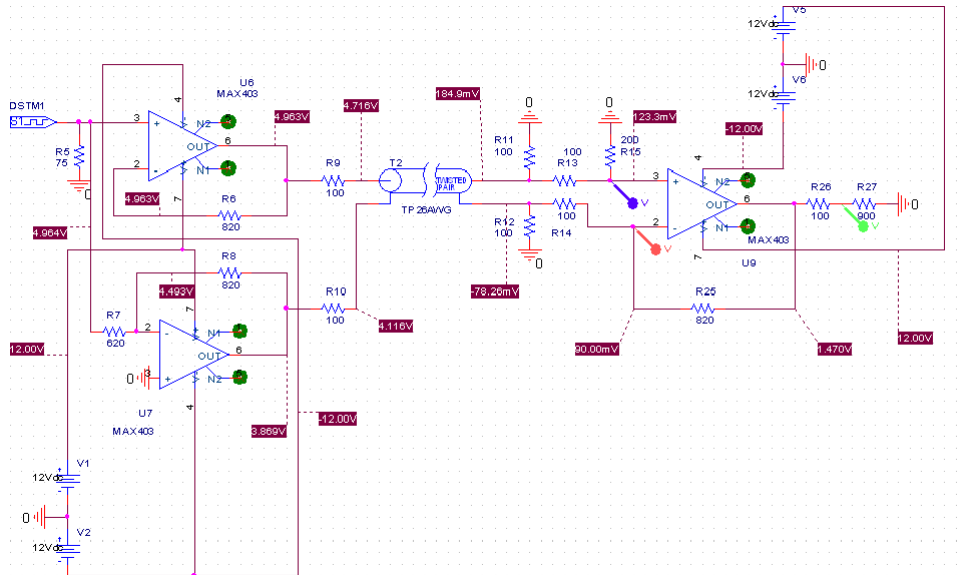

Figure 7 – Basic circuit of the receiving and transmitting path with voltage and current ratings

One of the simulation results is shown in the figure 8.

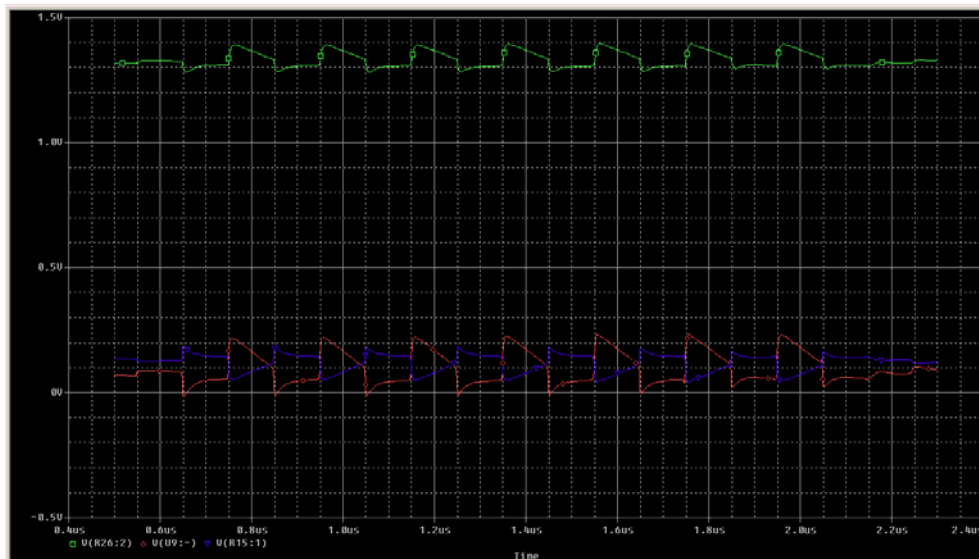

Figure 8 – Diagrams of antiphase signals U(U₉; N) and U(R₁₅; 1) at the output of a long line of and output signal U(R₂; 2) at 100 Mbit/s on the same scale

During a change of the data transfer rate over the TP26AWG twisted pair cable, there was a noticeable variation in the signal level and delay. With an increase in the signal transmission rate

compared to 10 Mbit/s, no significant changes in the amplitude were noticeable, but the signal delay was significantly reduced up to 10^{-3} seconds.

Conclusions. The long line based on a twisted pair TP26AWG and MAX403 operational amplifier was selected. The signal delay was reduced to 10^{-3} seconds. The signal amplitude became about 1 V, which allowed us to completely restore the received signal at the reception. Data transmission was simulated at 10 Mbit/s and 100 Mbit/s, which fully allowed transmitting a digital signal over a distance of more than half a kilometer with acceptable distortion.

М. Амреев¹, Р. Сафин², Т. Павлова¹, Э. К. Темырканова¹, Ю. Гармашова¹

¹Ғұмарбек Даукеев атындағы Алматы энергетика және байланыс университеті, Алматы, Қазақстан;

²Қазақ қатынас жолдары университеті, Алматы, Қазақстан

ҚАУІПСІЗДІК ТЕЛЕДИДАРЫНДАҒЫ БАЙЛАНЫС АРНАСЫ АРҚЫЛЫ КАМЕРА МЕН МОНИТОР АРАСЫНДАҒЫ САНДЫҚ СИГНАЛ КҮШЕЙТКІШІН ЖОБАЛАУ

Аннотация. Бейнебақылау жүйелерін пайдалану қауіпсіздік, заңдылық, құқық қорғау орындарында, күзетілетін нысандар аумағында, жол көлік құралдарының қозғалысын бақылау кезінде және басқа жерлерде қолданылады.

Бейнебақылау жүйесінің басты кемшілігі – ауа райының әсеріне бейімділігі (жанбыр, тұман, қар, т.б.) әрі бұл сигнал жүйесін азайту арқылы бейне жүйесінің сапасын төмендетеді.

Сондықтан бейне сигналдар сапасын жақсартудың жаңа жолдары мен мүмкіндіктерін іздеудің өзектілігі – сигнал өндеудің басым бағыттарының бірі болып саналады. Жұмыстың негізгі міндеті – негізгі параметрлерді анықтау, электр беру желісі мен күшейткішті имитациялау және кернеу мен ток көрсеткіштері арқылы беру және қабылдау жолының түбегейлі схемасын таңдау.

Қабылдағыштың да, кабельдік бейне таратқыштың да тарату желісінің әр түрлі ұзындығына арналған әртүрлі реттеу құралдары бар. Әрбір қабылдағыштың шығысындағы Сигнал 0,9-дан 1,1 В-қа дейінгі диапазонда болуы тиіс, ал қабылдағыштың кіреберісіндегі бейне беру желісі сымдарының жиынтық омдық кедергісінің шашырауы 2-3% - дан аспауы тиіс. Осы параметрлерге сүйене отырып, жабдық бейнені арна арқылы жіберуге бейімделеді.

Сәйкессіздік потенциометрлермен реттеледі, бұл бейне сигнал беру жабдықтарының жұмысын біркелкі реттеуге мүмкіндік береді [1].

Әдетте, канал арқылы бейне беру 50-ден 1500 м-ге дейінгі қашықтықта жүзеге асырылады. Егер бейнені 50 м-ден аз қашықтықта жіберу қажет болса, ресивер кірісінде қосымша кедергілер тізбектей қосылады, сонда жалпы сызық кедергісі 30 - 50 Ом болады [1].

Түйін сөздер: бейнебақылау, теледидарлық сигнал, жедел күшейткіш.

М. Амреев¹, Р. Сафин², Т. Павлова¹, Э. К. Темырканова¹, Ю. Гармашова¹

¹Алматинский университет энергетики и связи им. Гумарбека Даукеева, Алматы, Казахстан;

²Казахский университет путей сообщения, Алматы, Казахстан

ПРОЕКТИРОВАНИЕ УСИЛИТЕЛЯ ЦИФРОВОГО СИГНАЛА МЕЖДУ КАМЕРОЙ И МОНИТОРОМ ПО КАНАЛУ СВЯЗИ В ОХРАННОМ ТЕЛЕВИДЕНИИ

Аннотация. Применение систем видеонаблюдения применяется в зонах обеспечения безопасности, правопорядка, на территориях охраняемых объектов, при контроле за движением дорожных транспортных средств и в других зонах.

Основным недостатком системы видеонаблюдения является ее восприимчивость к погодным воздействиям (дождь, туман, снегопад и т.д.), что ухудшает качество работы видеосистемы за счет снижения уровня сигнала.

Поэтому актуальность поиска новых путей и возможностей повышения качества видеосигналов является одним из приоритетных направлений обработки сигналов. Основной задачей данной работы было опреде-

ление основных параметров, моделирование линии передачи и усилителя, а также выбор принципиальной схемы передающего и приемного тракта с номинальными напряжениями и токами.

И приемник, и кабельный видеопередатчик имеют различные средства настройки на различную длину линии передачи. Сигнал на выходе каждого приемника должен находиться в диапазоне от 0,9 до 1,1 В, а разброс суммарного омического сопротивления проводов линии видеопередачи на входе приемника должен составлять не более 2-3%. Исходя из этих параметров, оборудование настраивается на передачу видео по каналу. Величина рассогласования регулируется потенциометрами, которые позволяют плавно регулировать работу аппаратуры передачи видеосигнала [1].

Как правило, передача видео по каналу осуществляется на расстоянии от 50 до 1500 м. При необходимости передачи видеосигнала на расстояния менее 50 м на входе приемника последовательно подключаются дополнительные сопротивления так, чтобы общее сопротивление линии составляло 30-50 Ом [1].

Ключевые слова: видеонаблюдение, телевизионный сигнал, операционный усилитель.

Information about authors:

Amreyev M.B., doctor's degree, Almaty University of Power Engineering and Telecommunication, Almaty, Kazakhstan; max.amreev@gmail.com; <https://orcid.org/0000-0002-4874-1161>

Safin R.T., Senior lecturer of the Department «TCSS», Almaty University of Power Engineering and Telecommunication, Almaty, Kazakhstan; raf.safin@mail.ru; <https://orcid.org/0000-0003-1583-0034>

Pavlova T., Senior lecturer of the Department «TCSS», Almaty University of Power Engineering and Telecommunication, Almaty, Kazakhstan; t_sheh@mail.ru; <https://orcid.org/0000-0002-3063-8094>

Temyrkanova Elvira, PhD doctor, Associate Professor, Head of the Department of Telecommunications and Innovative Technologies»; <https://orcid.org/0000-0003-4059-5996>

Garmashova Y., MSc, docent of the Department «TCSS», Almaty University of Power Engineering and Telecommunication, Almaty, Kazakhstan; juliagarmashova@yandex.kz; <https://orcid.org/0000-0003-4267-3839>

REFERENCES

- [1] Mamiy A.R. Operational amplifiers. Maykop: ASU, 2005.
- [2] Efimov I.P. Operational amplifiers and their application. Ulyanovsk: UISTU, 2009.
- [3] Efimov I.E. Radio frequency transmission lines. M.: Svyaz – the Press, 2007.
- [4] Razevig V.D. ORCAD computer-automated design systems. M.: SOLON – the Press, 2003.
- [5] Determination of the Eb/N0 Ratio and Calculation of the Probability of an Error in the Digital Communication Chanel of the IP-Video Surveillance System./Статья/. Conference Computer Science and Information Technologies. Armenia, Yerevan, September 25-29, 2017. P. 386-389. ISBN 978-5-8080-0797-0
- [6] Study of a transmission-reception system of the voice signal of increased security on the basis of generator of chaotic oscillations.
- [7] Research and comparative analysis of phaso-inverter Cascades with single-polar power supply. International conference on Information science and communications Technologies 4-6 November, TUIT Campus, Local Hotels, Tashkent Uzbekistan.

**Publication Ethics and Publication Malpractice
in the journals of the National Academy of Sciences of the Republic of Kazakhstan**

For information on Ethics in publishing and Ethical guidelines for journal publication see <http://www.elsevier.com/publishingethics> and <http://www.elsevier.com/journal-authors/ethics>.

Submission of an article to the National Academy of Sciences of the Republic of Kazakhstan implies that the described work has not been published previously (except in the form of an abstract or as part of a published lecture or academic thesis or as an electronic preprint, see <http://www.elsevier.com/postingpolicy>), that it is not under consideration for publication elsewhere, that its publication is approved by all authors and tacitly or explicitly by the responsible authorities where the work was carried out, and that, if accepted, it will not be published elsewhere in the same form, in English or in any other language, including electronically without the written consent of the copyright-holder. In particular, translations into English of papers already published in another language are not accepted.

No other forms of scientific misconduct are allowed, such as plagiarism, falsification, fraudulent data, incorrect interpretation of other works, incorrect citations, etc. The National Academy of Sciences of the Republic of Kazakhstan follows the Code of Conduct of the Committee on Publication Ethics (COPE), and follows the COPE Flowcharts for Resolving Cases of Suspected Misconduct (http://publicationethics.org/files/u2/New_Code.pdf). To verify originality, your article may be checked by the Cross Check originality detection service <http://www.elsevier.com/editors/plagdetect>.

The authors are obliged to participate in peer review process and be ready to provide corrections, clarifications, retractions and apologies when needed. All authors of a paper should have significantly contributed to the research.

The reviewers should provide objective judgments and should point out relevant published works which are not yet cited. Reviewed articles should be treated confidentially. The reviewers will be chosen in such a way that there is no conflict of interests with respect to the research, the authors and/or the research funders.

The editors have complete responsibility and authority to reject or accept a paper, and they will only accept a paper when reasonably certain. They will preserve anonymity of reviewers and promote publication of corrections, clarifications, retractions and apologies when needed. The acceptance of a paper automatically implies the copyright transfer to the National Academy of Sciences of the Republic of Kazakhstan.

The Editorial Board of the National Academy of Sciences of the Republic of Kazakhstan will monitor and safeguard publishing ethics.

Правила оформления статьи для публикации в журнале смотреть на сайте:

www.nauka-nanrk.kz

ISSN 2518-170X (Online), ISSN 2224-5278 (Print)

<http://www.geolog-technical.kz/index.php/en/>

Редакторы *М. С. Ахметова, Д. С. Аленов, А. Ахметова*
Верстка *Д. А. Абдрахимовой*

Подписано в печать 01.02.2021.
Формат 70x881/8. Бумага офсетная. Печать – ризограф.
12,75 п.л. Тираж 300. Заказ 1.