

ISSN 2518-170X (Online),
ISSN 2224-5278 (Print)

ҚАЗАҚСТАН РЕСПУБЛИКАСЫ
ҰЛТТЫҚ ҒЫЛЫМ АКАДЕМИЯСЫНЫҢ
Қ. И. Сәтпаев атындағы Қазақ ұлттық техникалық зерттеу университеті

Х А Б А Р Л А Р Ы

ИЗВЕСТИЯ

НАЦИОНАЛЬНОЙ АКАДЕМИИ НАУК
РЕСПУБЛИКИ КАЗАХСТАН
Казахский национальный исследовательский
технический университет им. К. И. Сатпаева

NEWS

OF THE ACADEMY OF SCIENCES
OF THE REPUBLIC OF KAZAKHSTAN
Kazakh national research technical university
named after K. I. Satpayev

ГЕОЛОГИЯ ЖӘНЕ ТЕХНИКАЛЫҚ ҒЫЛЫМДАР СЕРИЯСЫ



СЕРИЯ ГЕОЛОГИИ И ТЕХНИЧЕСКИХ НАУК



SERIES OF GEOLOGY AND TECHNICAL SCIENCES

1 (427)

ҚАҢТАР – АҚПАН 2018 ж.
ЯНВАРЬ – ФЕВРАЛЬ 2018 г.
JANUARY – FEBRUARY 2018

ЖУРНАЛ 1940 ЖЫЛДАН ШЫҒА БАСТАҒАН
ЖУРНАЛ ИЗДАЕТСЯ С 1940 г.
THE JOURNAL WAS FOUNDED IN 1940.

ЖЫЛЫНА 6 РЕТ ШЫҒАДЫ
ВЫХОДИТ 6 РАЗ В ГОД
PUBLISHED 6 TIMES A YEAR

NAS RK is pleased to announce that News of NAS RK. Series of geology and technical sciences scientific journal has been accepted for indexing in the Emerging Sources Citation Index, a new edition of Web of Science. Content in this index is under consideration by Clarivate Analytics to be accepted in the Science Citation Index Expanded, the Social Sciences Citation Index, and the Arts & Humanities Citation Index. The quality and depth of content Web of Science offers to researchers, authors, publishers, and institutions sets it apart from other research databases. The inclusion of News of NAS RK. Series of geology and technical sciences in the Emerging Sources Citation Index demonstrates our dedication to providing the most relevant and influential content of geology and engineering sciences to our community.

Қазақстан Республикасы Ұлттық ғылым академиясы "ҚР ҰҒА Хабарлары. Геология және техникалық ғылымдар сериясы" ғылыми журналының Web of Science-тің жаңаланған нұсқасы Emerging Sources Citation Index-те индекстелуге қабылданғанын хабарлайды. Бұл индекстелу барысында Clarivate Analytics компаниясы журналды одан әрі the Science Citation Index Expanded, the Social Sciences Citation Index және the Arts & Humanities Citation Index-ке қабылдау мәселесін қарастыруда. Web of Science зерттеушілер, авторлар, баспашылар мен мекемелерге контент тереңдігі мен сапасын ұсынады. ҚР ҰҒА Хабарлары. Геология және техникалық ғылымдар сериясы Emerging Sources Citation Index-ке енуі біздің қоғамдастық үшін ең өзекті және беделді геология және техникалық ғылымдар бойынша контентке адалдығымызды білдіреді.

НАН РК сообщает, что научный журнал «Известия НАН РК. Серия геологии и технических наук» был принят для индексирования в Emerging Sources Citation Index, обновленной версии Web of Science. Содержание в этом индексировании находится в стадии рассмотрения компанией Clarivate Analytics для дальнейшего принятия журнала в the Science Citation Index Expanded, the Social Sciences Citation Index и the Arts & Humanities Citation Index. Web of Science предлагает качество и глубину контента для исследователей, авторов, издателей и учреждений. Включение Известия НАН РК. Серия геологии и технических наук в Emerging Sources Citation Index демонстрирует нашу приверженность к наиболее актуальному и влиятельному контенту по геологии и техническим наукам для нашего сообщества.

Б а с р е д а к т о р ы
э. ғ. д., профессор, ҚР ҰҒА академигі

И.К. Бейсембетов

Бас редакторының орынбасары

Жолтаев Г.Ж. проф., геол.-мин. ғ. докторы

Р е д а к ц и я а л қ а с ы:

Абаканов Т.Д. проф. (Қазақстан)
Абишева З.С. проф., академик (Қазақстан)
Агабеков В.Е. академик (Беларусь)
Алиев Т. проф., академик (Әзірбайжан)
Бакиров А.Б. проф., (Қырғыстан)
Беспаев Х.А. проф. (Қазақстан)
Бишимбаев В.К. проф., академик (Қазақстан)
Буктуков Н.С. проф., академик (Қазақстан)
Булат А.Ф. проф., академик (Украина)
Ганиев И.Н. проф., академик (Тәжікстан)
Грэвис Р.М. проф. (АҚШ)
Ерғалиев Г.К. проф., академик (Қазақстан)
Жуков Н.М. проф. (Қазақстан)
Кенжалиев Б.К. проф. (Қазақстан)
Қожахметов С.М. проф., академик (Қазақстан)
Конторович А.Э. проф., академик (Ресей)
Курскеев А.К. проф., академик (Қазақстан)
Курчавов А.М. проф., (Ресей)
Медеу А.Р. проф., академик (Қазақстан)
Мұхамеджанов М.А. проф., корр.-мүшесі (Қазақстан)
Нигматова С.А. проф. (Қазақстан)
Оздоев С.М. проф., академик (Қазақстан)
Постолатий В. проф., академик (Молдова)
Ракишев Б.Р. проф., академик (Қазақстан)
Сейтов Н.С. проф., корр.-мүшесі (Қазақстан)
Сейтмуратова Э.Ю. проф., корр.-мүшесі (Қазақстан)
Степанец В.Г. проф., (Германия)
Хамфери Дж.Д. проф. (АҚШ)
Штейнер М. проф. (Германия)

«ҚР ҰҒА Хабарлары. Геология мен техникалық ғылымдар сериясы».

ISSN 2518-170X (Online),

ISSN 2224-5278 (Print)

Меншіктенуші: «Қазақстан Республикасының Ұлттық ғылым академиясы» РҚБ (Алматы қ.).

Қазақстан республикасының Мәдениет пен ақпарат министрлігінің Ақпарат және мұрағат комитетінде 30.04.2010 ж. берілген №10892-Ж мерзімдік басылым тіркеуіне қойылу туралы куәлік.

Мерзімділігі: жылына 6 рет.

Тиражы: 300 дана.

Редакцияның мекенжайы: 050010, Алматы қ., Шевченко көш., 28, 219 бөл., 220, тел.: 272-13-19, 272-13-18,
<http://nauka-nanrk.kz/geology-technical.kz>

© Қазақстан Республикасының Ұлттық ғылым академиясы, 2018

Редакцияның Қазақстан, 050010, Алматы қ., Қабанбай батыра көш., 69а.

мекенжайы: Қ. И. Сәтбаев атындағы геология ғылымдар институты, 334 бөлме. Тел.: 291-59-38.

Типографияның мекенжайы: «Аруна» ЖК, Алматы қ., Муратбаева көш., 75.

Г л а в н ы й р е д а к т о р
д. э. н., профессор, академик НАН РК

И. К. Бейсембетов

Заместитель главного редактора

Жолтаев Г.Ж. проф., доктор геол.-мин. наук

Р е д а к ц и о н н а я к о л л е г и я:

Абаканов Т.Д. проф. (Казахстан)
Абишева З.С. проф., академик (Казахстан)
Агабеков В.Е. академик (Беларусь)
Алиев Т. проф., академик (Азербайджан)
Бакиров А.Б. проф., (Кыргызстан)
Беспаяев Х.А. проф. (Казахстан)
Бишимбаев В.К. проф., академик (Казахстан)
Буктуков Н.С. проф., академик (Казахстан)
Булат А.Ф. проф., академик (Украина)
Ганиев И.Н. проф., академик (Таджикистан)
Грэвис Р.М. проф. (США)
Ергалиев Г.К. проф., академик (Казахстан)
Жуков Н.М. проф. (Казахстан)
Кенжалиев Б.К. проф. (Казахстан)
Кожаметов С.М. проф., академик (Казахстан)
Конторович А.Э. проф., академик (Россия)
Курскеев А.К. проф., академик (Казахстан)
Курчавов А.М. проф., (Россия)
Медеу А.Р. проф., академик (Казахстан)
Мухамеджанов М.А. проф., чл.-корр. (Казахстан)
Нигматова С.А. проф. (Казахстан)
Оздоев С.М. проф., академик (Казахстан)
Постолатий В. проф., академик (Молдова)
Ракишев Б.Р. проф., академик (Казахстан)
Сейтов Н.С. проф., чл.-корр. (Казахстан)
Сейтмуратова Э.Ю. проф., чл.-корр. (Казахстан)
Степанец В.Г. проф., (Германия)
Хамфери Дж.Д. проф. (США)
Штейнер М. проф. (Германия)

«Известия НАН РК. Серия геологии и технических наук».

ISSN 2518-170X (Online),

ISSN 2224-5278 (Print)

Собственник: Республиканское общественное объединение «Национальная академия наук Республики Казахстан (г. Алматы)

Свидетельство о постановке на учет периодического печатного издания в Комитете информации и архивов Министерства культуры и информации Республики Казахстан №10892-Ж, выданное 30.04.2010 г.

Периодичность: 6 раз в год

Тираж: 300 экземпляров

Адрес редакции: 050010, г. Алматы, ул. Шевченко, 28, ком. 219, 220, тел.: 272-13-19, 272-13-18,
<http://nauka-nanrk.kz/geology-technical.kz>

© Национальная академия наук Республики Казахстан, 2018

Адрес редакции: Казахстан, 050010, г. Алматы, ул. Кабанбай батыра, 69а.

Институт геологических наук им. К. И. Сатпаева, комната 334. Тел.: 291-59-38.

Адрес типографии: ИП «Аруна», г. Алматы, ул. Муратбаева, 75

NEWS

OF THE NATIONAL ACADEMY OF SCIENCES OF THE REPUBLIC OF KAZAKHSTAN

SERIES OF GEOLOGY AND TECHNICAL SCIENCES

ISSN 2224-5278

Volume 1, Number 427 (2018), 61 – 68

UDC 007+681.322+681.5.015.42

B. S. Akhmetov¹, A. I. Ivanov², Zh. K. Alimseitova³¹Kazakh national pedagogical university named after Abai, Almaty, Kazakhstan,²Penza state university, Penza, Russia,³Kazakh national research technical university named after K. I. Satpayev, Almaty, Kazakhstan.

E-mail: zhuldyz_al@mail.ru

**TRAINING OF NEURAL NETWORK
BIOMETRY-CODE CONVERTERS**

Abstract. There are considered theoretical and practical issues of training of neural network biometric parameters converters into the key code on the example of the handwriting dynamics. The researches were carried out in the simulation environment of the «NeuroTrader» in the modes of manual and automatic training. Analysis of research results has shown that for sustainable learning there is a need in a large number of examples or the use of a composite adder. The resulting neural network container allows safely and anonymously to store a biometric pattern.

Key words: neuron, neural network converter, training, weight coefficient, adder.

Introduction. The development of information technology, informatization of society leads to an increase in the requirements for information security systems, including protection against unauthorized access. The reason for this is an increase in the volume of stored and transmitted information, the number of electronic services, the possibility of distance access to information, distance learning, and etc.

Analysis of the existing modern authentication systems shows that most systems use a password authentication. The obvious disadvantage of this system is long passwords, which are hard to remember. As a consequence, they are recorded, that leads to their loss, divulgence, theft. Alternative to password authentication are biometric systems which use the unique biometric parameters of a particular user as a key.

The advantages of biometric authentication include the possibility of implementation on computer hardware, the complexity of compromising, substitution, the possibility to authenticate at entering the system and during its operation. As biometric parameters there are used finger- and palmprints, geometric parameters of hands, face, ears, drawing of the eye iris or its retina, features of handwriting or keyboard handwriting, voice.

In recent years a widespread distribution has received the authentication based on handwriting, the prospect of which is confirmed by the fairly wide distribution of such authentication tools, as well as a large number of relevant theoretical and practical researches [1-6]. At the same time, their use is limited by relatively low recognition accuracy, a significant development time, insufficient adaptation to many features of modern IT, which predetermines the relevance of researches in this direction.

Problem statement. The analysis of works devoted to biometric user authentication show that this process can be divided into several stages, for example, such as reading a biometric parameter, highlighting of features and a biometric pattern forming, adding a pattern to the database. The resulting biometric pattern should be unique and protected. Obtaining of a biometric pattern from a biometric parameter leads to the question of image recognition. This problem is successfully solved by using artificial neural networks.

Purpose and objectives of the research. In accordance with the general problem of the researches in the field of neural network systems of biometric user authentication, the main purpose of the research is the training of artificial neural networks for the handwriting recognition.

Training of a neural network converter. In accordance with GOST R 52633.0 [7] the neural network converter of biometry-code must be trained in advance to convert the secret biometric image of "Own" into a user's private key. Training should be carried out automatically (without human intervention in the process of selecting the parameters of an artificial neural network), the user must have assurance that his long password (key) involved in training will not be compromised.

The general scheme for training of the neural network biometric parameters converter into the key code is shown in figure 1 [8].

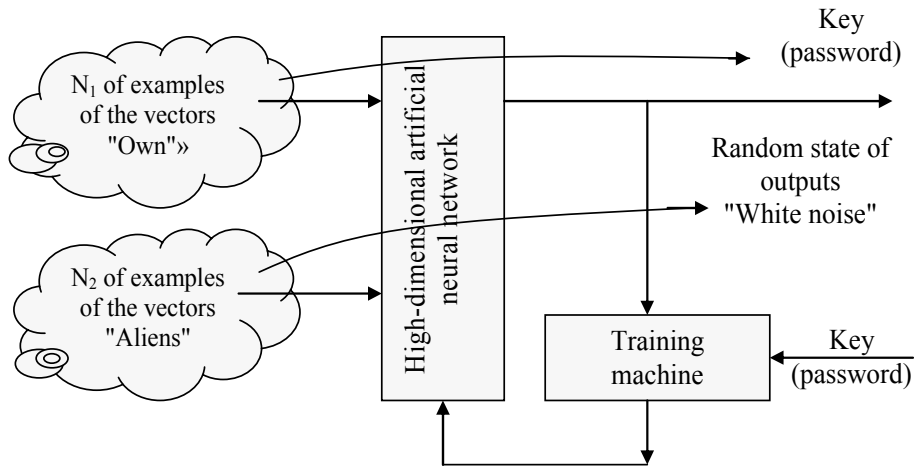

Figure1 – The structural scheme of training of the neural network biometric parameters converter into the key code (password)

The training is carried out by alternately presenting of the "Own" and "Alien" images to the learning machine with an intermediate selection of the coefficients of the artificial neural network [9-11]. The weight coefficients should be selected in such a way when during the appearance at the inputs of the artificial neural network of the "Own" vector elements there appears a long password (key) at the outputs of the artificial neural network. During the appearance at the inputs of the artificial neural network of data vectors corresponding to the images "Alien", at the outputs of the artificial neural network there should appear random states – "white noise" [12].

Let's consider the training process using the example of a degenerate neural network converter biometry-code with one output [13, 14], shown in figure 2.

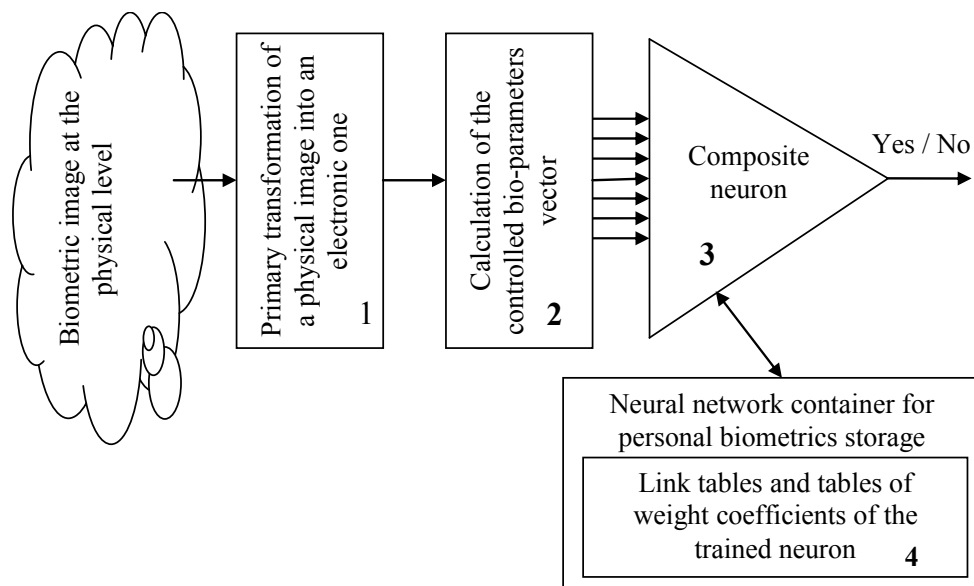

Figure 2 – A degenerate neural network converter biometry-code with one composite neuron

It is clear that the training of one neuron does not represent a particular difficulty, and for this purpose there can be used any of the hundreds of currently known learning algorithms [15-20].

In order to illustrate the training process we will use the "NeuroTrader"'s modeling environment. As a biometric image we will select the handwriting dynamics, will form a training sample from several examples of "Own" and from several examples of "Alien".

As examples of the image of "Own" we will use 13 handwritten images of the word "Almaty", reproduced by the same person (figure 3).

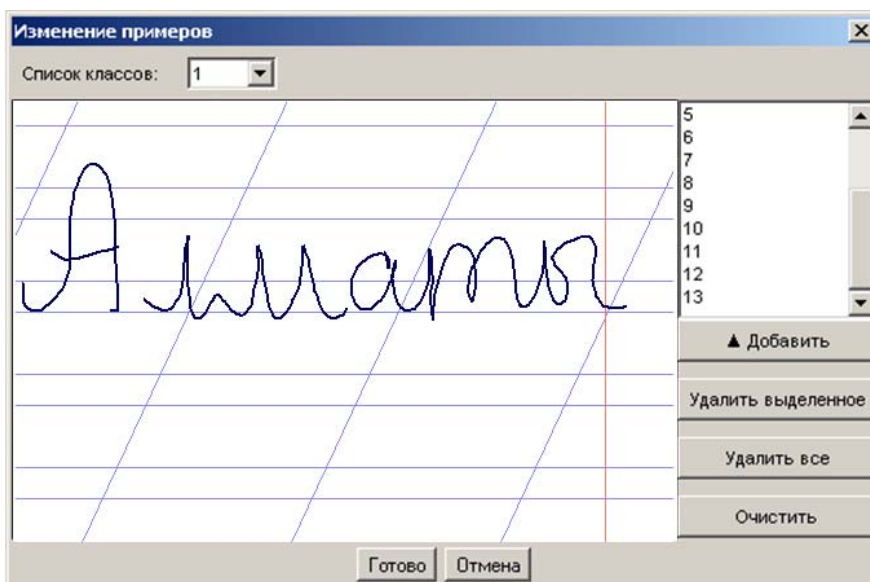

Figure3 – The screen entering form of the examples of the handwritten password "Own" in the "NeuroTrader" modeling environment

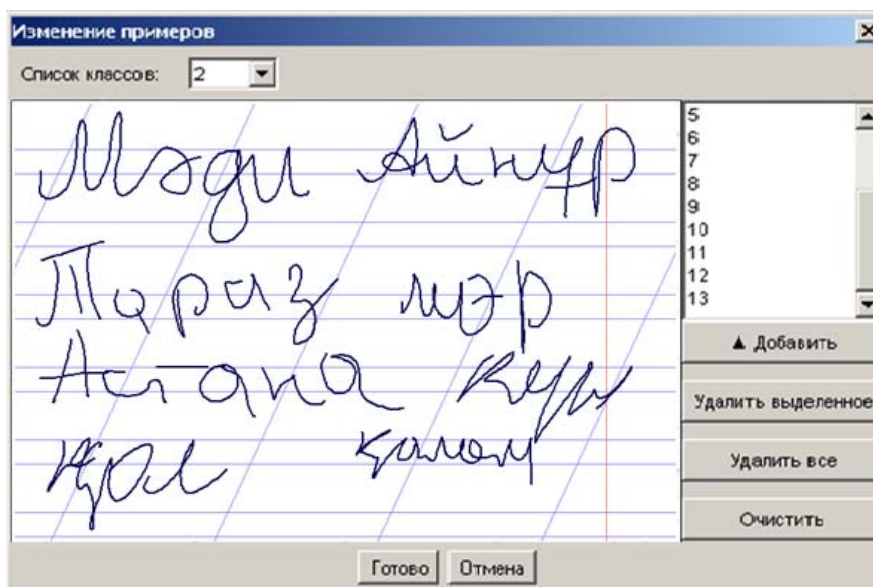

Figure 4 – The screen entering form of the examples of the handwritten images "Aliens" in the "NeuroTrader" modeling environment

As images of "Aliens" there were used the words "Madi", "Ainur", "Taraz", "mor", "Astana", "kun", "kol", "kalam" (figure 4), reproduced handwritten by different people. Therefore, at training a neuron it is necessary to select its weight coefficients in such a way that the set of images "Alien" and the set of examples of one image of "Own" were as much as possible spaced at the output of the adder of the neuron. As a rule, as an euron there is considered an adder with some nonlinear element at the output.

As analyzing parameters the modeling environment "NeuroTrader" uses the Fourier coefficients of the pen oscillations resulting from the handwritten reproduction of the analyzed words. Figure 5 shows an example of such oscillations.

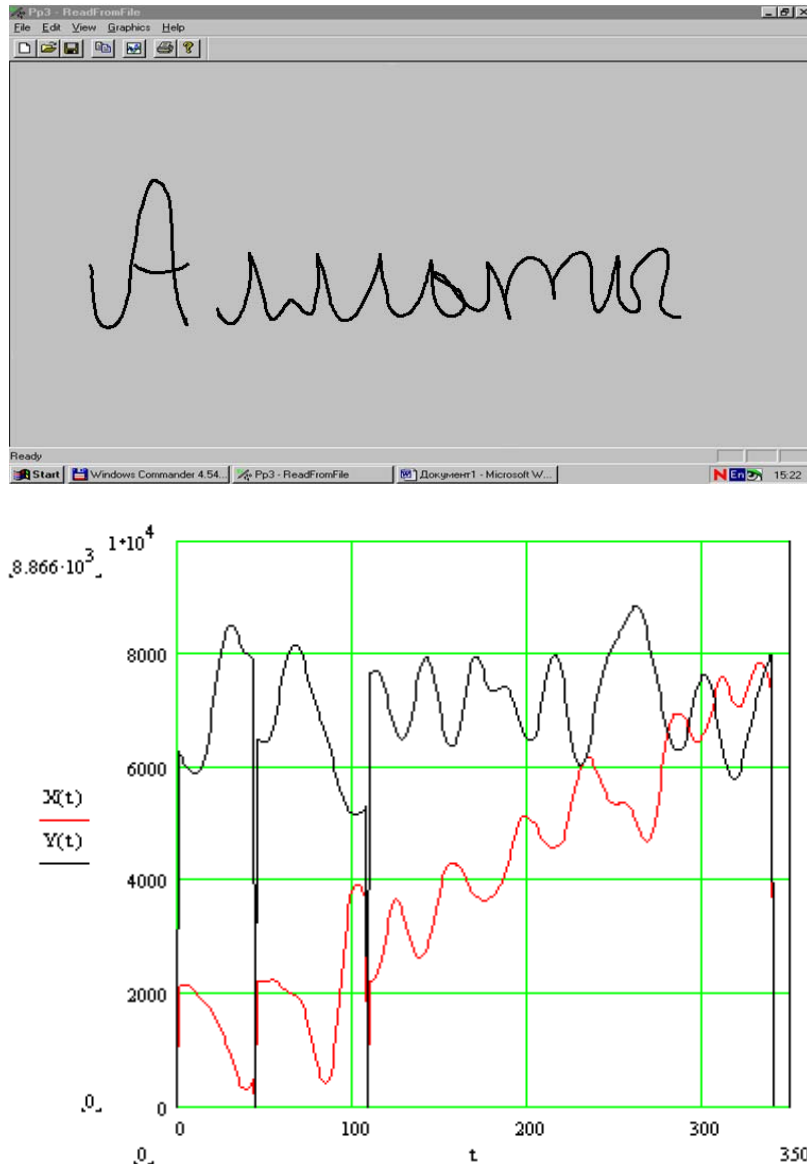

Figure 5 – Example of the pen oscillations Y(t) and X(t) at the handwritten reproduction of the word-password «Almaty»

Practice has shown that for handwritten words of 4, 5, 6 letters it is sufficient to take into account about 24 of cosine and sinus coefficients of the Fourier series ($k = 1, 2, 3, \dots, 24$). Then taking into account two coordinates makes it possible to obtain a vector from 96 biometric parameters (1-4):

$$v_k = \frac{1}{T} \int_0^T Y(t) \cdot \cos\left(k \frac{2\pi}{T} t\right) dt, \quad (1); \quad v_{2k} = \frac{1}{T} \int_0^T Y(t) \cdot \sin\left(k \frac{2\pi}{T} t\right) dt \quad (2);$$

$$v_{3k} = \frac{1}{T} \int_0^T X(t) \cdot \cos\left(k \frac{2\pi}{T} t\right) dt, \quad (3); \quad v_{4k} = \frac{1}{T} \int_0^T X(t) \cdot \sin\left(k \frac{2\pi}{T} t\right) dt \quad (4);$$

where T – full time for entering a signature (handwritten word-password).

As a result, during the training of a neuron it is necessary to select iteratively its weight coefficients – μ_i of all inputs of the adder. If we denote through $z(\bar{v})$ the output responses of the adder to the images of "Own", then we get following:

$$z(\bar{v}) = \mu_0 + \sum_{i=1}^{96} \mu_i v_i \quad (5)$$

Since we need that all the examples of the hand written word "Almaty" give are spons eat the output of the neuron "1", then the adjustment of the single nonlinear element must be carried out according to the following rule:

$$\begin{cases} y(\xi_i) = "0" & \text{if } \xi_i < \min(z(\bar{v}_i)); \\ y(\xi_i) = "1" & \text{if } \xi_i \geq \min(z(\bar{v}_i)) \end{cases} \quad (6)$$

Unfortunately, the adjustment (selection) of 96 weight coefficients of the neuron can not always be performed automatically using 13 examples of the images "Own" and "Aliens" in the training sample. For normal algorithms there are no problems with automatic training only when the number of inputs of the trainee neuron is close to the number of examples in the training sample.

In our situation, the number of examples is not sufficient for sustainable training. In this regard, the neuron adder should be made composite, as it is shown on figure 6.

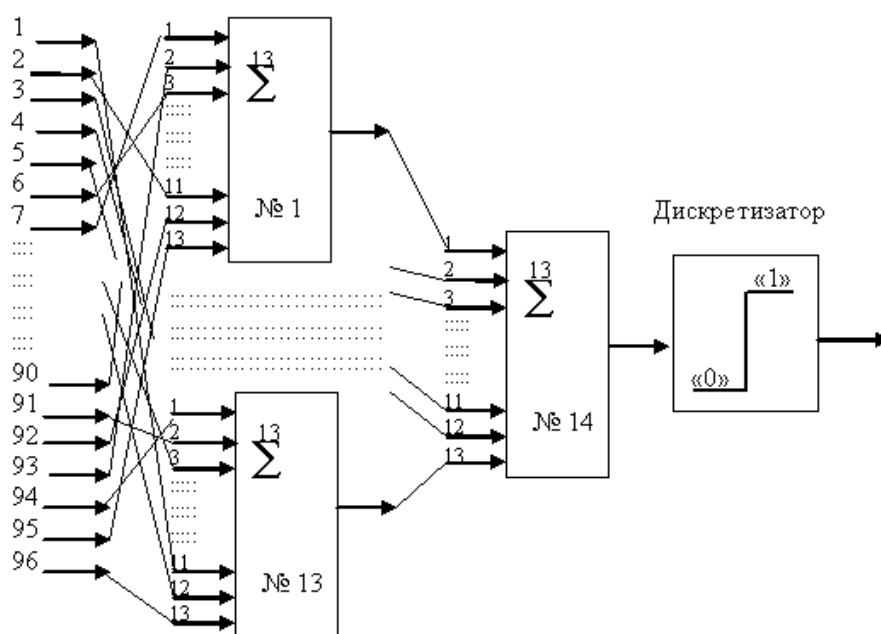

Figure 6 – Artificial neuron with composite adders

In order to train each of the 14 adders of the composite neuron it is sufficient to have a training sample of 13 examples, because each adder has 13 inputs (the number of inputs does not exceed the number of examples). Organizing a composite adder it is recommended to connect randomly each of the adders of the first layer to the inputs of the neuron. Obviously, it is necessary to trace the fact of all the inputs using.

Each of the adders of the first layer is trained independently on the examples of the images "Own" and "Aliens". When all the adders of the first layer are trained, the data of the examples from their inputs are translated to the outputs of the adders and further are used in training the single adder of the second layer. There are no nonlinear elements at the outputs of the adders of the first layer, that allow to consider all adders as one adder with a large number of inputs. The decomposition of the complete training task into 14 simpler subtasks is only necessary for the automatic training mode. In the mode of manual training

of a neuron (such a mode in the modeling environment "NeuroTrader" is available) you can achieve satisfactory results.

The results of the automatic training of the last adder of the composite neuron are shown in figure 7.

It should be noted that a positive fact that information about the parameters of a trained neuron is much more difficult to use than information in a biometric pattern. The conditions for the formation of the biometric pattern directly indicate the position of the controlled biometric parameters.

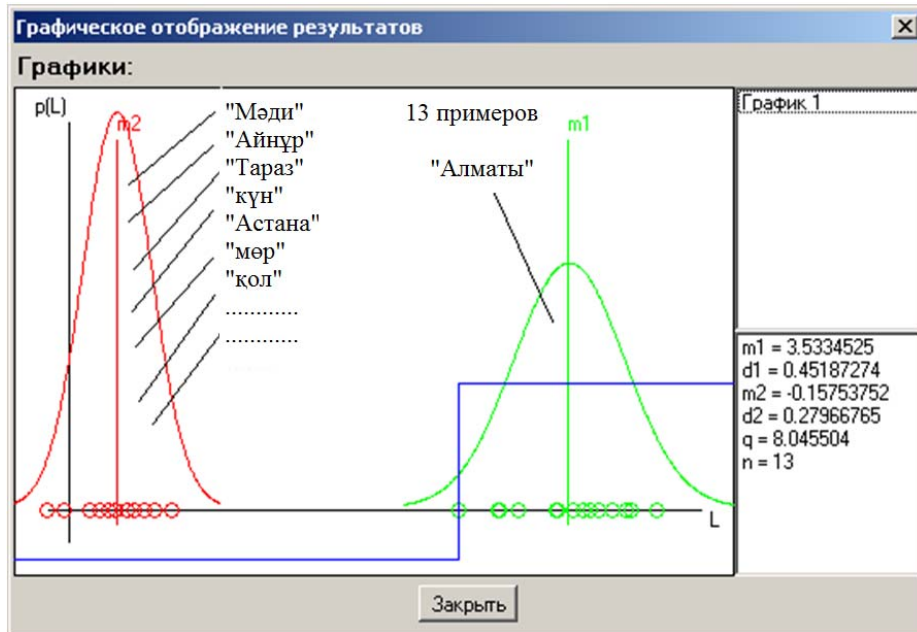

Figure 7 – The screen entering form of the neuron training results in the "NeuroTrader" modeling environment

The situation is completely different with the weight coefficients and connections of the trained composite neuron. According to them it is impossible to specify exactly where the appearance of the biometric parameters "Own" should be expected. An example of link tables of a composite neuron and the weight coefficients of a trained composite neuron is shown in figure 8.

Neural network container for secure (open or anonymous or impersonal) storage of biometrics	
Link tables of the inputs and outputs of adders of a composite neuron	Table of weight coefficients of neuron trained adders
70 19 18 46 10 13 94 90 23 42 64 46 60	+94-05-84-40+95-54+70-26-53-40+59-69+44
86 63 57 19 56 25 61 59 50 75 63 81 58	-01-61-58+23-31-09-86+82+70+54+15-73-14
92 73 67 32 31 11 86 16 08 65 55 41 47	+65-09-95-28+99-30-37-22+25-91+71+29+18
16 74 83 88 34 13 79 61 48 36 11 23 92	-78-22-01+12 +32+04-19+16+89-20 -65-91-93
67 50 15 51 69 61 01 11 87 75 39 56 96	-16+57+95-58-26-36-80-08+60+20 -65-61+45

Figure 8 – Example of a neural network container with the placed in it biometric parameters of the trained composite neuron

Figure 8 shows that the information placed in the so-called biometric container is very similar to cipher text. It can not be interpreted as simply as information from a biometric pattern. In this respect, the use of artificial neural networks should be considered as one of the methods of hiding of personal biometric user information.

Conclusions:

1. For normal algorithms there are no problems with automatic training only when the number of inputs of the trainee neuron is close to the number of examples in the training sample
2. In case when the number of examples is not sufficient for sustainable training, the neuron adder should be made composite.
3. Organizing a composite adder it is recommended to connect randomly each of the adders of the first layer to the inputs of the neuron.
4. The use of artificial neural networks should be considered as one of the methods of hiding of personal biometric user information

REFERENCES

- [1] Gonzales R., Vuds R. Cifrovaja obrabotka izobrazhenij. M.: Tehnosfera, 2006. 1072 p.
- [2] Demin A.A. Adaptivnaja obrabotka kalligraficheskoy informacii, predstavlennoj v vide rukopisnyh simbolov: Dis. kand. tehn. nauk: 05.13.01 / Demin A.A. M., 2014. 182 p.
- [3] Korchenko A. Nejrosetevye modeli, metody i sredstva ocenki parametrov bezopasnosti Internet-orientirovannyh informacionnyh sistem: monografija / A. Korchenko, I Terejkovskij, N. Karpinskij, S. Tynymbaev. K.: TOV «NashFormat». 2016. 275 p.
- [4] Terejkovskij I. Nejronnimerzhivzasobahzahistu komp'yuternoï informacii / I. Terejkovskij. K.: PoligrafKonsalting, 2007. 209 p.
- [5] Hurshudov A.A. Razrabotka sistemy raspoznavanija vizual'nyh obrazov v potokedannyh: Dis. kand. tehn. nauk: 05.13.01 / Hurshudov A.A. Krasnodar, 2015. 130 p.
- [6] Ahmetov B., Terejkovskaja L., Terejkovskij I., Alimseitova Zh. Opredelenie optimal'nogo tipa nejrosetevoj modeli dlja biometricheskoy autentifikacii // Sbornik trudov IV Mezhdunarodnoj nauchno-prakticheskoy konferencii «Intellektual'nye informacionnye kommunikacionnye tehnologii – sredstvo osushhestvlenija tret'ej industrial'noj revoljucii v svete Strategii «Kazahstan-2050»» posvjashhennoj 70-letiju professora M. Bejsenbi. Astana: ENU im. L. N. Gumileva, 2017. P. 155-157.
- [7] RMG R 52633.0. Information protection. Information protection technology. Requirements to the means of high-reliability biometric authentication. M.: Russia, 2007. (In Russian)
- [8] Akhmetov B.S., Ivanov A.I., Malygin A.Ju., Funtikov V. A. Osnovy biometricheskoy autentifikacii lichnosti: ucheb. posobie. Almaty: KazNTU imeni K. I. Satpaeva, 2014. 122 p.
- [9] Akhmetov B.S., Volchihin V.I., Malygin A.Ju., Ivanov A.I. Algoritmy testirovanija biometriko-nejrosetevyih mehanizmov zashhity informacii: monografija. Almaty: Izd-vo Kazahskogo nacional'nogo tehnicheskogo un-ta, 2013. 160 p.
- [10] Akhmetov B.S., Ivanov A.I., Funtikov V.A., Bezjaev A.V., Malygina E.A. Tehnologija ispol'zovanija bol'shih nejronnyh setej dlja preobrazovanija nechetkih biometricheskikh dannyh v kod kljucha dostupa: Monografija. Almaty: KazNTU imeni K. I. Satpaeva, 2014. 102 p.
- [11] Malygin A.Ju., Akhmetov B.S. i dr. Uchet vlijanija korreljacionnyh svjazej na rezul'taty testirovanija preobrazovatelej biometrija-kod // Informacionnye telekommunikacionnye tehnologii: obrazovanie, nauka, praktika: Sb. tr. mezhd. nauch.-prakt. konf. Almaty: KazNTU, 2012. P. 34–37.
- [12] Akhmetov B.S., Ivanov A.I., Kartbaev T.S., Malygin A.U., Mukapil K. Biometric Dynamic Personality Authentication in Open Information Space. Computer Technology & Applications. 2013. Vol. 4(5). P. 846-855.
- [13] Akhmetov B.S., Ivanov A.I., Kartbayev T.S., Kalizhanova A., Mukapil K. Testing the Quality of Teaching the Biometrical-code Transformers. Procedia – Social and Behavioral Sciences (Elsevier). 2015. Vol. 191. P. 2261-2266. DOI:10.1016/j.sbspro.2015.04.557
- [14] Akhmetov B.S., Kartbayev T.S., Doszhanova A.A. and others. Developmen of a computer system for identity authentication using artifical neural networks. Image Analysis & Stereology. 2017. Vol. 36, N 1. P. 51-64. DOI: 10.5566/ias.1612 Available online at: <http://www.jas-iss.org/ojs/IAS/issue/view/140>
- [15] Sajmon Hajkin. Nejronnye seti: Polnyj kurs. 2nd publ. M.: Vil'jams, 2008. P. 1103.
- [16] Ahmetov B.S., Gorbachenko V.I. Nejronnye seti: Uchebnik. Almaty: KazNITU imeni K. I. Satpaeva, 2016. 256 p.
- [17] Galushkin A.I. Nejronnye seti: osnovy teorii. M.: Gorjachaja linija - Telekom, 2017. 496 p.
- [18] Golovko V.A. Nejronnye seti: obuchenie, organizacijai primenenie. M.: IPRZHR, 2001. 256 p.
- [19] Gorban' A.N. Obuchenie nejronnyh setej. M.: Paragraf, 1990. 156 p.
- [20] Kruglov V.V., Borisov V.V. Iskusstvennye nejronnye seti: Teorija i praktika. M.: Gorjachaja linija - Telekom, 2002. 382 p.

Б. С. Ахметов¹, А. И. Иванов², Ж. К. Алимсеитова³

¹Абай атындағы Қазақ ұлттық педагогикалық университеті, Алматы, Қазақстан,

²Пензальск мемлекеттік университет, Пенза, Ресей,

³Қ.И. Сәтбаев атындағы Қазақ ұлттық техникалық зерттеу университеті, Алматы, Қазақстан

БИОМЕТРИЯ-КОД НЕЙРОЖЕЛІЛІК ТҮРЛЕНДІРГІШТЕРДІ ОҚЫТУ

Аннотация. Қол жазба өзгерісі мысалында биометриялық параметрлердің нейрожелілік түрлендіргіштерін кілт кодына оқытудың теориялық және тәжірибелік сұрақтары қарастырылады. Зерттеулер «НейроПреподаватель» модельдеу ортасында қолдан оқыту және автоматты оқыту режимдерінде жүргізілді. Зерттеу нәтижелері тұрақты оқыту үшін көп мысалдар қажет екенін немесе құрамдас сумматор керек екенін көрсетті. Нәтижеде алынған нейрожелілік контейнер биометриялық үлгіні қауіпсіз және жасырын сақтауға мүмкіндік береді.

Түйін сөздер: нейрон, нейрожелілік түрлендіргіш, оқыту, салмақтық коэффициент, сумматор.

Б. С. Ахметов¹, А. И. Иванов², Ж. К. Алимсеитова³

¹Казахский национальный педагогический университет им. Абая, Алматы, Казахстан,

²Пензенский государственный университет, Пенза, Россия,

³Казахский национальный исследовательский технический университет им. К. И. Сатпаева, Алматы, Казахстан.

ОБУЧЕНИЕ НЕЙРОСЕТЕВЫХ ПРЕОБРАЗОВАТЕЛЕЙ БИОМЕТРИЯ–КОД

Аннотация. Рассматриваются теоретические и практические вопросы обучения нейросетевых преобразователей биометрических параметров в код ключа на примере динамики рукописного почерка. Исследования проводились в среде моделирования «НейроПреподаватель» в режимах ручного и автоматического обучения. Анализ результатов исследований показал, что для устойчивого обучения необходимо большое число примеров либо использование составного сумматора. Полученный в результате нейросетевой контейнер позволяет безопасно и анонимно хранить биометрический шаблон.

Ключевые слова: нейрон, нейросетевой преобразователь, обучение, весовой коэффициент, сумматор.

Сведения об авторах:

Ахметов Б.С. – д.т.н., профессор кафедры "Информатика и информатизация образования" Казахского национального педагогического университета им. Абая.

Иванов А.И. – д.т.н., профессор Пензенского государственного университета.

Алимсеитова Ж.К. – лектор кафедры "Информационная безопасность" Казахского национального исследовательского технического университета им. К. И. Сатпаева.

**Publication Ethics and Publication Malpractice
in the journals of the National Academy of Sciences of the Republic of Kazakhstan**

For information on Ethics in publishing and Ethical guidelines for journal publication see <http://www.elsevier.com/publishingethics> and <http://www.elsevier.com/journal-authors/ethics>.

Submission of an article to the National Academy of Sciences of the Republic of Kazakhstan implies that the described work has not been published previously (except in the form of an abstract or as part of a published lecture or academic thesis or as an electronic preprint, see <http://www.elsevier.com/postingpolicy>), that it is not under consideration for publication elsewhere, that its publication is approved by all authors and tacitly or explicitly by the responsible authorities where the work was carried out, and that, if accepted, it will not be published elsewhere in the same form, in English or in any other language, including electronically without the written consent of the copyright-holder. In particular, translations into English of papers already published in another language are not accepted.

No other forms of scientific misconduct are allowed, such as plagiarism, falsification, fraudulent data, incorrect interpretation of other works, incorrect citations, etc. The National Academy of Sciences of the Republic of Kazakhstan follows the Code of Conduct of the Committee on Publication Ethics (COPE), and follows the COPE Flowcharts for Resolving Cases of Suspected Misconduct (http://publicationethics.org/files/u2/New_Code.pdf). To verify originality, your article may be checked by the Cross Check originality detection service <http://www.elsevier.com/editors/plagdetect>.

The authors are obliged to participate in peer review process and be ready to provide corrections, clarifications, retractions and apologies when needed. All authors of a paper should have significantly contributed to the research.

The reviewers should provide objective judgments and should point out relevant published works which are not yet cited. Reviewed articles should be treated confidentially. The reviewers will be chosen in such a way that there is no conflict of interests with respect to the research, the authors and/or the research funders.

The editors have complete responsibility and authority to reject or accept a paper, and they will only accept a paper when reasonably certain. They will preserve anonymity of reviewers and promote publication of corrections, clarifications, retractions and apologies when needed. The acceptance of a paper automatically implies the copyright transfer to the National Academy of Sciences of the Republic of Kazakhstan.

The Editorial Board of the National Academy of Sciences of the Republic of Kazakhstan will monitor and safeguard publishing ethics.

Правила оформления статьи для публикации в журнале смотреть на сайте:

www.nauka-nanrk.kz

ISSN 2518-170X (Online), ISSN 2224-5278 (Print)

<http://geolog-technical.kz/index.php/kz/>

Верстка Д. Н. Калкабековой

Подписано в печать 13.02.2018.
Формат 70x881/8. Бумага офсетная. Печать – ризограф.
12,0 п.л. Тираж 300. Заказ 1.