

ISSN 2518-170X (Online),
ISSN 2224-5278 (Print)

ҚАЗАҚСТАН РЕСПУБЛИКАСЫ
ҰЛТТЫҚ ҒЫЛЫМ АКАДЕМИЯСЫНЫҢ
Қ. И. Сәтпаев атындағы Қазақ ұлттық техникалық зерттеу университеті

Х А Б А Р Л А Р Ы

ИЗВЕСТИЯ

НАЦИОНАЛЬНОЙ АКАДЕМИИ НАУК
РЕСПУБЛИКИ КАЗАХСТАН
Қазақстан Республикасының Ғылым Академиясының
Қ. И. Сәтпаев атындағы Қазақ ұлттық техникалық зерттеу университеті

NEWS

OF THE ACADEMY OF SCIENCES
OF THE REPUBLIC OF KAZAKHSTAN
Kazakh national research technical university
named after K. I. Satpayev

SERIES OF GEOLOGY AND TECHNICAL SCIENCES

6 (438)

NOVEMBER – DECEMBER 2019

THE JOURNAL WAS FOUNDED IN 1940

PUBLISHED 6 TIMES A YEAR

ALMATY, NAS RK

NAS RK is pleased to announce that News of NAS RK. Series of geology and technical sciences scientific journal has been accepted for indexing in the Emerging Sources Citation Index, a new edition of Web of Science. Content in this index is under consideration by Clarivate Analytics to be accepted in the Science Citation Index Expanded, the Social Sciences Citation Index, and the Arts & Humanities Citation Index. The quality and depth of content Web of Science offers to researchers, authors, publishers, and institutions sets it apart from other research databases. The inclusion of News of NAS RK. Series of geology and technical sciences in the Emerging Sources Citation Index demonstrates our dedication to providing the most relevant and influential content of geology and engineering sciences to our community.

Қазақстан Республикасы Ұлттық ғылым академиясы "ҚР ҰҒА Хабарлары. Геология және техникалық ғылымдар сериясы" ғылыми журналының Web of Science-тің жаңаланған нұсқасы Emerging Sources Citation Index-те индекстелуге қабылданғанын хабарлайды. Бұл индекстелу барысында Clarivate Analytics компаниясы журналды одан әрі the Science Citation Index Expanded, the Social Sciences Citation Index және the Arts & Humanities Citation Index-ке қабылдау мәселесін қарастыруда. Web of Science зерттеушілер, авторлар, баспашылар мен мекемелерге контент тереңдігі мен сапасын ұсынады. ҚР ҰҒА Хабарлары. Геология және техникалық ғылымдар сериясы Emerging Sources Citation Index-ке енуі біздің қоғамдастық үшін ең өзекті және беделді геология және техникалық ғылымдар бойынша контентке адалдығымызды білдіреді.

НАН РК сообщает, что научный журнал «Известия НАН РК. Серия геологии и технических наук» был принят для индексирования в Emerging Sources Citation Index, обновленной версии Web of Science. Содержание в этом индексировании находится в стадии рассмотрения компанией Clarivate Analytics для дальнейшего принятия журнала в the Science Citation Index Expanded, the Social Sciences Citation Index и the Arts & Humanities Citation Index. Web of Science предлагает качество и глубину контента для исследователей, авторов, издателей и учреждений. Включение Известия НАН РК. Серия геологии и технических наук в Emerging Sources Citation Index демонстрирует нашу приверженность к наиболее актуальному и влиятельному контенту по геологии и техническим наукам для нашего сообщества.

Б а с р е д а к т о р ы
э. ғ. д., профессор, ҚР ҰҒА академигі

И.К. Бейсембетов

Бас редакторының орынбасары

Жолтаев Г.Ж. проф., геол.-мин. ғ. докторы

Р е д а к ц и я а л қ а с ы:

Абаканов Т.Д. проф. (Қазақстан)
Абишева З.С. проф., академик (Қазақстан)
Агабеков В.Е. академик (Беларусь)
Алиев Т. проф., академик (Әзірбайжан)
Бакиров А.Б. проф., (Қырғыстан)
Беспәев Х.А. проф. (Қазақстан)
Бишимбаев В.К. проф., академик (Қазақстан)
Буктуков Н.С. проф., академик (Қазақстан)
Булат А.Ф. проф., академик (Украина)
Ганиев И.Н. проф., академик (Тәжікстан)
Грэвис Р.М. проф. (АҚШ)
Ерғалиев Г.К. проф., академик (Қазақстан)
Жуков Н.М. проф. (Қазақстан)
Қожахметов С.М. проф., академик (Қазақстан)
Конторович А.Э. проф., академик (Ресей)
Курскеев А.К. проф., академик (Қазақстан)
Курчавов А.М. проф., (Ресей)
Медеу А.Р. проф., академик (Қазақстан)
Мұхамеджанов М.А. проф., корр.-мүшесі (Қазақстан)
Нигматова С.А. проф. (Қазақстан)
Оздоев С.М. проф., академик (Қазақстан)
Постолатий В. проф., академик (Молдова)
Ракишев Б.Р. проф., академик (Қазақстан)
Сейтов Н.С. проф., корр.-мүшесі (Қазақстан)
Сейтмуратова Э.Ю. проф., корр.-мүшесі (Қазақстан)
Степанец В.Г. проф., (Германия)
Хамфери Дж.Д. проф. (АҚШ)
Штейнер М. проф. (Германия)

«ҚР ҰҒА Хабарлары. Геология мен техникалық ғылымдар сериясы».

ISSN 2518-170X (Online),

ISSN 2224-5278 (Print)

Меншіктенуші: «Қазақстан Республикасының Ұлттық ғылым академиясы» РҚБ (Алматы қ.).

Қазақстан республикасының Мәдениет пен ақпарат министрлігінің Ақпарат және мұрағат комитетінде 30.04.2010 ж. берілген №10892-Ж мерзімдік басылым тіркеуіне қойылу туралы куәлік.

Мерзімділігі: жылына 6 рет.

Тиражы: 300 дана.

Редакцияның мекенжайы: 050010, Алматы қ., Шевченко көш., 28, 219 бөл., 220, тел.: 272-13-19, 272-13-18,
<http://www.geolog-technical.kz/index.php/en/>

© Қазақстан Республикасының Ұлттық ғылым академиясы, 2019

Редакцияның Қазақстан, 050010, Алматы қ., Қабанбай батыра көш., 69а.

мекенжайы: Қ. И. Сәтбаев атындағы геология ғылымдар институты, 334 бөлме. Тел.: 291-59-38.

Типографияның мекенжайы: «Аруна» ЖК, Алматы қ., Муратбаева көш., 75.

Г л а в н ы й р е д а к т о р
д. э. н., профессор, академик НАН РК

И. К. Бейсембетов

Заместитель главного редактора

Жолтаев Г.Ж. проф., доктор геол.-мин. наук

Р е д а к ц и о н н а я к о л л е г и я:

Абаканов Т.Д. проф. (Казахстан)
Абишева З.С. проф., академик (Казахстан)
Агабеков В.Е. академик (Беларусь)
Алиев Т. проф., академик (Азербайджан)
Бакиров А.Б. проф., (Кыргызстан)
Беспаяев Х.А. проф. (Казахстан)
Бишимбаев В.К. проф., академик (Казахстан)
Буктуков Н.С. проф., академик (Казахстан)
Булат А.Ф. проф., академик (Украина)
Ганиев И.Н. проф., академик (Таджикистан)
Грэвис Р.М. проф. (США)
Ергалиев Г.К. проф., академик (Казахстан)
Жуков Н.М. проф. (Казахстан)
Кожаметов С.М. проф., академик (Казахстан)
Конторович А.Э. проф., академик (Россия)
Курскеев А.К. проф., академик (Казахстан)
Курчавов А.М. проф., (Россия)
Медеу А.Р. проф., академик (Казахстан)
Мухамеджанов М.А. проф., чл.-корр. (Казахстан)
Нигматова С.А. проф. (Казахстан)
Оздоев С.М. проф., академик (Казахстан)
Постолатий В. проф., академик (Молдова)
Ракишев Б.Р. проф., академик (Казахстан)
Сейтов Н.С. проф., чл.-корр. (Казахстан)
Сейтмуратова Э.Ю. проф., чл.-корр. (Казахстан)
Степанец В.Г. проф., (Германия)
Хамфери Дж.Д. проф. (США)
Штейнер М. проф. (Германия)

«Известия НАН РК. Серия геологии и технических наук».

ISSN 2518-170X (Online),

ISSN 2224-5278 (Print)

Собственник: Республиканское общественное объединение «Национальная академия наук Республики Казахстан (г. Алматы)

Свидетельство о постановке на учет периодического печатного издания в Комитете информации и архивов Министерства культуры и информации Республики Казахстан №10892-Ж, выданное 30.04.2010 г.

Периодичность: 6 раз в год

Тираж: 300 экземпляров

Адрес редакции: 050010, г. Алматы, ул. Шевченко, 28, ком. 219, 220, тел.: 272-13-19, 272-13-18,
<http://nauka-nanrk.kz/geology-technical.kz>

© Национальная академия наук Республики Казахстан, 2019

Адрес редакции: Казахстан, 050010, г. Алматы, ул. Кабанбай батыра, 69а.

Институт геологических наук им. К. И. Сатпаева, комната 334. Тел.: 291-59-38.

Адрес типографии: ИП «Аруна», г. Алматы, ул. Муратбаева, 75

E d i t o r i n c h i e f

doctor of Economics, professor, academician of NAS RK

I. K. Beisembetov

Deputy editor in chief

Zholtayev G.Zh. prof., dr. geol-min. sc.

E d i t o r i a l b o a r d:

Abakanov T.D. prof. (Kazakhstan)
Abisheva Z.S. prof., academician (Kazakhstan)
Agabekov V.Ye. academician (Belarus)
Aliyev T. prof., academician (Azerbaijan)
Bakirov A.B. prof., (Kyrgyzstan)
Bespayev Kh.A. prof. (Kazakhstan)
Bishimbayev V.K. prof., academician (Kazakhstan)
Buktukov N.S. prof., academician (Kazakhstan)
Bulat A.F. prof., academician (Ukraine)
Ganiyev I.N. prof., academician (Tadjikistan)
Gravis R.M. prof. (USA)
Yergaliev G.K. prof., academician (Kazakhstan)
Zhukov N.M. prof. (Kazakhstan)
Kozhakhmetov S.M. prof., academician (Kazakhstan)
Kontorovich A.Ye. prof., academician (Russia)
Kurskeyev A.K. prof., academician (Kazakhstan)
Kurchavov A.M. prof., (Russia)
Medeu A.R. prof., academician (Kazakhstan)
Muhamedzhanov M.A. prof., corr. member. (Kazakhstan)
Nigmatova S.A. prof. (Kazakhstan)
Ozdoev S.M. prof., academician (Kazakhstan)
Postolatii V. prof., academician (Moldova)
Rakishev B.R. prof., academician (Kazakhstan)
Seitov N.S. prof., corr. member. (Kazakhstan)
Seitmuratova Ye.U. prof., corr. member. (Kazakhstan)
Stepanets V.G. prof., (Germany)
Humphery G.D. prof. (USA)
Steiner M. prof. (Germany)

News of the National Academy of Sciences of the Republic of Kazakhstan. Series of geology and technology sciences.

ISSN 2518-170X (Online),

ISSN 2224-5278 (Print)

Owner: RPA "National Academy of Sciences of the Republic of Kazakhstan" (Almaty)

The certificate of registration of a periodic printed publication in the Committee of information and archives of the Ministry of culture and information of the Republic of Kazakhstan N 10892-Ж, issued 30.04.2010

Periodicity: 6 times a year

Circulation: 300 copies

Editorial address: 28, Shevchenko str., of. 219, 220, Almaty, 050010, tel. 272-13-19, 272-13-18,
<http://nauka-nanrk.kz/geology-technical.kz>

© National Academy of Sciences of the Republic of Kazakhstan, 2019

Editorial address: Institute of Geological Sciences named after K.I. Satpayev
69a, Kabanbai batyr str., of. 334, Almaty, 050010, Kazakhstan, tel.: 291-59-38.

Address of printing house: ST "Aruna", 75, Muratbayev str, Almaty

NEWS

OF THE NATIONAL ACADEMY OF SCIENCES OF THE REPUBLIC OF KAZAKHSTAN

SERIES OF GEOLOGY AND TECHNICAL SCIENCES

ISSN 2224-5278

Volume 6, Number 438 (2019), 46 – 53

<https://doi.org/10.32014/2019.2518-170X.154>

UDC 622.24.25.5

M. Biletsky¹, IU. Nifontov², B. Ratov³, D. Deliskesheva¹

¹NAO Kazakh National Research Technical University named after K. I. Satpayev, Almaty, Kazakhstan,

²Saint-Petersburg State Marine Technical University, Russia,

³Caspian Public University, Almaty, Kazakhstan.

E-mail: biletskymarc@yandex.ru, nifontovy@yandex.ru, ratov.bt@gmail.com, delikeshiva@mail.ru

THE PROBLEM OF DRILLING MUD PARAMETERS CONTINUOUS MONITORING AND ITS SOLUTION AT THE EXAMPLE OF AUTOMATIC MEASUREMENT OF ITS DENSITY

Abstract. For the most part the cause of down-the-hole problems while drilling wells consists in the fact, that the properties of the drilling muds don't meet the requirements of the well's geologic and technological conditions. At present those properties are measured manually and at lengthy time intervals. Attempts at automatic measurement of drilling muds density, by means of sensors, based upon various physical phenomena, have proved unsuccessful. It is explained by extremely great variety of drilling muds compositions and properties. Decades of the traditional manual measurements have proved that their methods as such are the best in meeting the well drilling specifics. Automatization of the traditional manual measurements allows to perform them at the pre-planned periodicity and eliminates the need in specially trained staff. The problem is solved by placing the traditional measuring instruments on the revolving table. The electrical measurement signal is transformed into digital form, permitting demonstration the drilling mud parameters on the driller's panel, as well as registering them in the memory. Automatic monitoring of the drilling mud parameters and their density in particular makes it possible to reduce costs of eliminating geological problems while drilling. The appliances in question can be used at all rigs drilling wells for oil gas, water and hard mineral resources.

Key words: drilling wells, opposing the geological problems, drilling muds parameters, automatization of measurements, demonstration on the driller's panel, automatic density meter.

Publications analysis and problem formulation. The drilling process can be reduced to the well face destruction with a rock destruction tool. The particles of the rock are transported from the well face to the surface by the circulating flow of drilling mud. Its descending flow is travelling along the drill string internal channel to the well face and therefrom, saturated with the destruction products, returns to the surface along the annulus between the well bore and the drill string.

Apart from the function of the well face cleaning from the cuttings the drilling mud fulfills a number of other functions. An important role of the drilling muds in technology of well drilling and finishing is represented in both classical [1] and modern [2] publications. A special attention is paid to the role of drilling muds in down-the-holes problems control. It is believed [3], that on the average about 10 % of well construction costs make up the costs of down-the-hole break downs eliminations. The modern situation in the drilling muds technology with prognosis for the future is described in the work [4]. The publications [5,6] are devoted to muds helping keep the well bore stable and, in particular, under the bulging clays conditions [7]. A special attention is paid to the muds intended for prevention of outbreaks and gushers of formation fluids [8].

The muds composition, their formulae are reflected in their measurable parameters, such as density, viscosity, filtration, gel strength, yield point, cuttings content, power of hydrogen etc. The availability of

the mud, needed for controlling the certain kind of drilling problem, is ascertained by obtaining the corresponding combination of its measurable parameters.

Modern drilling rigs are equipped with instruments for the drilling process automatic continuous monitoring. Thus a Japanese rig of Koken Boring Machines [9] company provides for automatic measurement of such parameters as bit load, its rotation frequency, flush fluid flow rate, its pressure, penetration rate, rotary torque etc – 12 parameters altogether. Their values are demonstrated on display panel, assuring an immediate reaction of the driller on their spontaneous changes. However among those parameters the drilling muds quality characteristics are absent.

To-day, like many decades ago, the drilling muds quality parameters are measured by single point measurements, performed manually [1, 10]. The mean intervals between measurements are as long as several hours, and often they are performed sporadically. The cause consists in a certain complicacy and durability of the manual measurement procedure. Such being the practice, the danger of grave down-the-hole problems is always present.

By means of the drilling mud density the hydrostatic pressure in the well is controlled, which plays decisive role in prevention of the formation fluids' blow outs and gushers. In order to damp down an abnormal formation pressures muds of high density are used. Contrariwise, in case of the flush fluid absorption in the well bore the hydrostatic pressure must be kept as low as possible. But on both occasions the dead line must be observed, when hydrostatic pressure building up brings about the formation fracturing, and its dropping – the inflow of the formation fluids in the well bore with corresponding problems.

A superfluous –in the context of the problems preventing – drilling mud density enhances the drilling pump energy expenditures, and reduces its interrepair period. Besides, the density increase sharply reduces the penetration rate.

In the course of penetration the values of mud density are changing and first of all due to its saturation with cuttings. Sudden density changes can signalize on sharp changes of drilling environments. A dated as recently as 2017 publication [11], headed “Real time monitoring system improves drilling efficiencies” points out that “Direct and rapid measurements of drilling fluids characteristics allow to evaluate the deviation from planned baseline and take immediate actions to recover optimum drilling condition”. The authors are adducing examples of problems caused by belated information about density and viscosity of drilling mud. The first example is related to the fact, when for that reason the well was completed 70 days later, than it had been planned. In the second example, besides essential loss of time for the failure elimination, the bottom diameter of the well had to be reduced from 8 ½ to 5 ¾ inches which brought about corresponding reduction of productivity.

In the work [12] a scheme of automatic control of drilling mud density in accordance with changing environment is considered. The authors stressed, that such an objective can only be gained on condition, that instruments of continuous monitoring of that parameter are available.

In current publications there are references to automatic meters of the fluid flow density. The work [13], discussing methods of opposing well bore cavings, submits an idea of application automatic meters of drilling mud density. The author points out, that by working principle such instruments may be electromagnetic, thermal or acoustic. However the work does not contain any specific information as to their design, mounting, or performance under conditions of drilled well.

The work[14] contains proposal to use the Coriolis mass flow meter, capable to measure density as well. At present that instrument is used with oil products and other one phase fluids. However it is mentioned in the publication, that a negative impact on that meter's performance can be produced by the changes of the liquid's viscosity and temperature and by presence of solids in it, particularly of their large particles. Presence of gases requires raising the pressure in the line up to one or even several MPa. But drilling muds usually represent double phase fluids, and they may contain particles of solids of various sizes (from several microns to several millimeters). In the course of penetration the muds' parameters are changing, both continuously and stepwise. The above mentioned limitations, with the Coriolis appliance being mounted in the injection line of the drilling pump, would require repeated resetting as best, and may end in its failure as worst. In the reverse line of mud circulation such a meter cannot be placed absolutely, because of low (atmospheric) pressure and presence of cuttings. What follows is, that the wide use of the Coriolis mass flow meter for measuring drilling mud density monitoring is highly problematic.

In the work [15] a simple method of drilling mud density measuring is proposed. In the stand pipe of the drilling pump's injection line (that is, in its vertical sector) two manometers are positioned – one of them at the bottom, another at the top. The authors are pointing out, that the interval of heights being known, the difference of the manometers' readings characterize the mud's density. However it is true only on condition that the liquid's circulation is ceased. If the liquid is circulating (as it always does while drilling) from the mentioned pressure difference the viscous pressure drop on the stand pipe has to be deducted. Those last are proposed by the authors to find by theoretical calculation, based upon the liquid's known flow rate and viscosity. Thus the flow meter and viscometer must be present in the injection line of the pump. That makes the problem much more complicated and particularly in view of the fact, that existing viscometers are intended only for performing one point measurements. In view of those facts, and taking into account, that flow rate and viscosity of drilling muds are highly variable while drilling, the problem of using the above mentioned method for continuous monitoring the drilling mud density looks intractable

Attempts at automatization of the drilling mud density measurements were made since many years ago [16], but they have not found industrial implementation. It was because of the meter's complicated structure and of the fact that it could not measure the mud density in the injection line, being intended for mounting in the gutters and pits of the mud circulation system surface section.

The purpose of this research is providing for continuous automatic monitoring the drilling mud quality parameters in general and its density in particular. In order to achieve that purpose, objectives as follows are to be gained:

1. To carry out analysis of the publications, capable to contribute to achievement of the purpose.
2. To propose a general principle of the drilling muds' quality parameters measurement automatization.
3. To develop a general scheme of the continuous automatic monitoring of the drilling muds quality parameters.
4. To apply the general scheme for working out the structure of the drilling muds density continuous automatic monitoring.

The works on achieving the planned objectives. The publications analysis has shown, that because of complexity and vast variety of the flushing agents as to their intention, composition, physical and chemical properties, as well as high degree of their spontaneous changeability, the use of automatic density meters from other industries involves many arduous problems. A conclusion was made, that the problem of automatic continuous measurement of the drilling mud density (as well as of a number of another quality parameters) can be most effectively solved by way of automatization of the traditional manual methods of measurements [17-21]. It will involve advantages as follows:

- The decades of practical use of those methods have proved their effectiveness and versatility: they can be used with all types of drilling where the flushing liquids are used
- Unlike physical methods (realized by electromagnetic, acoustic, accelerative, thermal etc sensors), the traditional methods are not subject to physical disturbances
- The use of traditional methods is contributing to continuity of the existing drilling technology

The capital defect of the traditional methods is the fact, that they are only realized manually by single point measurements, which makes continuous monitoring impossible. Automatization of the traditional manual methods will provide for:

- Establishing a distinct periodicity of the measurements with reduction of the assigned period to the reasonable minimum
- Reduction of time needed for the measurement procedure by removal of preparative and concluding operations like preparation and setting the meter, collecting the mud's sample, washing up the appliance after measurement, data registration etc.
- Improving the measurement accuracy by distinct automatic fixing the borders between successive operations and removing subjective errors caused by human factor
- linking-up emergency signaling
- Obtaining electrical measurement signal with its subsequent converting into digital form with possibility of:

- Demonstrating the mud parameters readings on the driller's panel along with other technological parameters, which will supplement the general picture of drilling conditions and contribute to accurate diagnosis of the current problems
- Registering the mud measurement data in the time succession in the memory, with possibility of retracting them whenever a need arises
- Amplifying the obtained information by means of its processing according to a special program
- Incorporating the drilling mud measurement signals into systems of automatic control of the drilling process.

At the Kazakh Satpajev National Research Technological university Drilling Wells Technology department a general approach to drilling mud parameters continuous monitoring was worked out. Its basic principle is automatization of the traditional manual method.

The general scheme of such an approach can be reduced to following:

The general procedure and instruments of the traditional measurement methods are left intact. However for the purpose of their automatization a number of new elements are added. Among them the most essential are:

- Revolving round table;
- Organs of its control;
- Sensors of converting the measured value into electrical signal;
- Analog-digital converter;
- Display;
- Memory.

Revolving at a planned frequency, the table is capable to make halts in the assigned positions, such as loading the measuring capacity with a sample of the mud, performing the measurement as such; cleaning the measuring capacity from the traces of the mud after the measurement has been completed.

Basing upon the general scheme, a structure of the drilling mud density continuous automatic monitoring was elaborated. It is shown on the figures 1 and 2.

The appliance is operating as follows:

The supplied with cams disk of the time relay 10 is revolved by a synchronous motor (not shown) with a strictly constant frequency. Just before the situation shown at the fig.1, the table 1 was at rest in the "wash up" position. The funnel 4 by means of the delivered from the tank 23 by the pump 20 through the channel 24 stream of water was being cleaned from the traces of the drilling mud 7.

After the planned for the "wash-up" time has elapsed, the cam 17^I on the disk 10 closed the dead contact 14 and supplied voltage U_{II} from its source to the terminals of the relay 11. The tongue 12 of the relay, having been displaced to the right, closed the dead contact 13, supplying voltage to the motor 2 and thereby resuming the motion of the table 1.

At the beginning of the table's motion its cam 18^I, which at the "wash-up" position had been pushing on the live contact 16, keeping it open, – lets it free, which brings about its closing. Due to the fact that the rotation speed of the table 1 is higher than that of the disk 10, the contact 16 is closed earlier than the cam 17^I has left the contact 14 and made it open. Apart from starting the table the tongue 12 with its left end is closing the contact 15 of the relay's lockup. For that reason after the cam 17^I has left the contact 14, the voltage goes on being supplied to the relay 11 and motor 2 through contacts 15, 16, 13.

One more consequence of the table's resuming its motion is the fact that the cam 21, which during all the period of the "wash up" halt had kept the dead contact (not shown) closed, supplying the voltage to the pump's 20 motor, – left the contact, allowing it to open and causing the pump to stop delivering water

When continuing its revolution, the table takes position II "loading and measurement", the cam 18^{II} meets the live contact 16 and opens it. The relay 11 is de-energized and its tongue, moving by its spring to the left leaves dead contacts 13 and 15 and opens them. The motor 2 and the table 1 cease revolving, the funnel 4 taking position right under the channel 6, delivering the stream of the drilling mud.

The mud enters the funnel at its top and leaves it at its bottom through the orifice of the nipple. As the flow Q^1 designedly surpasses the flow Q^2 (limited with the small size of the nipple's orifice) the funnel is being gradually filled with the mud. The funnel's weight is growing and, contracting the spring 5, it is settling down. When doing that, the funnel is shifting the slide contact 8 along the rheochord 9 in the direction of growth of the output voltage U . However for the time being that voltage is actually absent, because the dead contact 22, (through which variable resistor's feeding voltage U_{II} is delivered) is open.

Ultimately the mud starts spilling over the funnel edge into the mud pump's receiving tank, and from that moment on, the funnel's weight is kept at maximum value. The situation is preserved till the moment, when after a predetermined time interval the cam 17^{II} of the time relay 10 approaches the dead contact 14 and, actuating the starting relay 11, resumes the table's revolving. At the very instant of the table's leaving the position II the cam 19 (figures 1 and 2) passes the dead contact 22 and, closing it, delivers the voltage U_{II} to the variable resistor 8, causing appearance of the voltage U . That voltage is proportional to the weight of the loaded with mud funnel (minus the weight of the funnel itself, corresponding to the set-point position of the sliding contact 8).

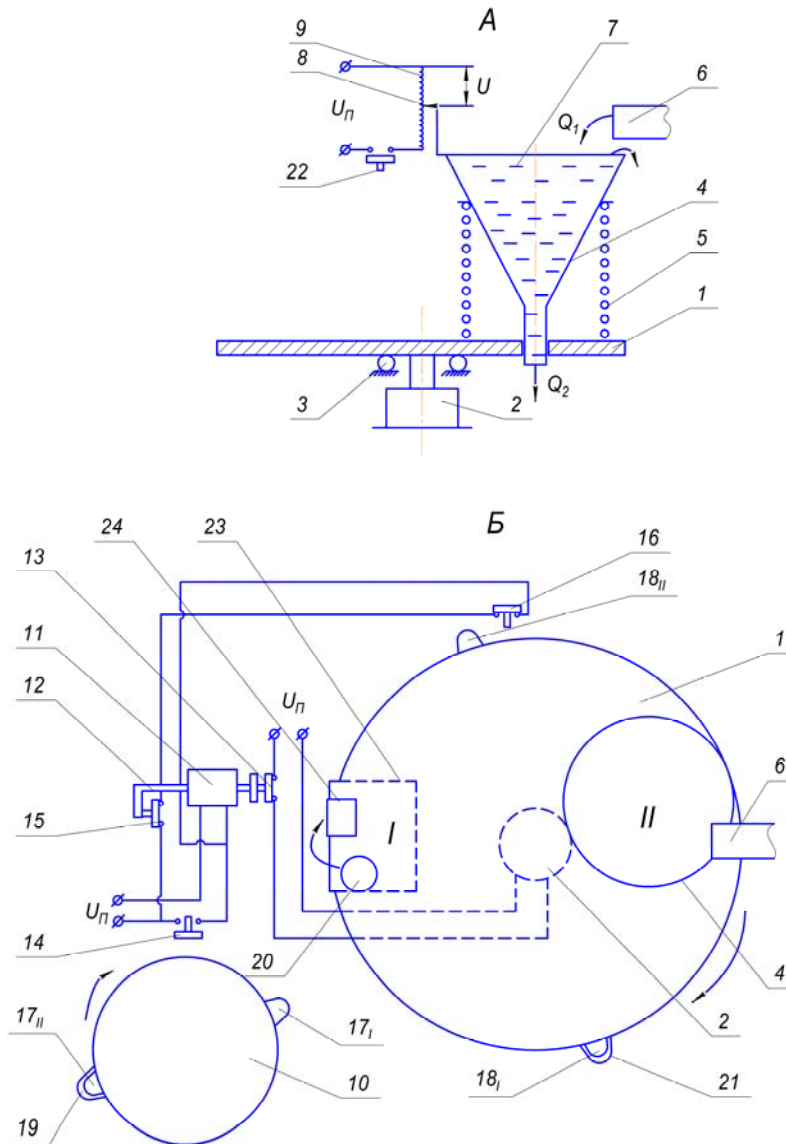

Figure 1 – The appliance for drilling mud density automatic monitoring.

A – side view: filling the funnel with mud; B – face view with electrical circuit; I – wash up position; II –filling up and measurement position; 1 – table; 2 – electric motor; 3 – bearing; 4 – funnel; 5 – spring; 6 – mud delivery channel; 7 – mud; 8 – sliding contact; 9 – rheochord; 10 – time relay; 11 – starting relay; 12 tongue; 13,14, 15, 22 – dead contacts; 16 – live contact; 17^I – cam of revolution resumption from the position I; 17^{II} – the same from the position II; 18^I – cam for halting in the position I; 18^{II} – the same in the position II; 19 – cam for voltage delivery to the variable resistor (located beneath the cam 17^{II}); 20 – water pump; 21 – cam for the water pump starting (located beneath the cam 18^I); 23 – water tank; 24 – water delivery channel; Q^1 and Q^2 – mud flows; U_{II} – feed voltage; U – outlet voltage (the measurement signal).

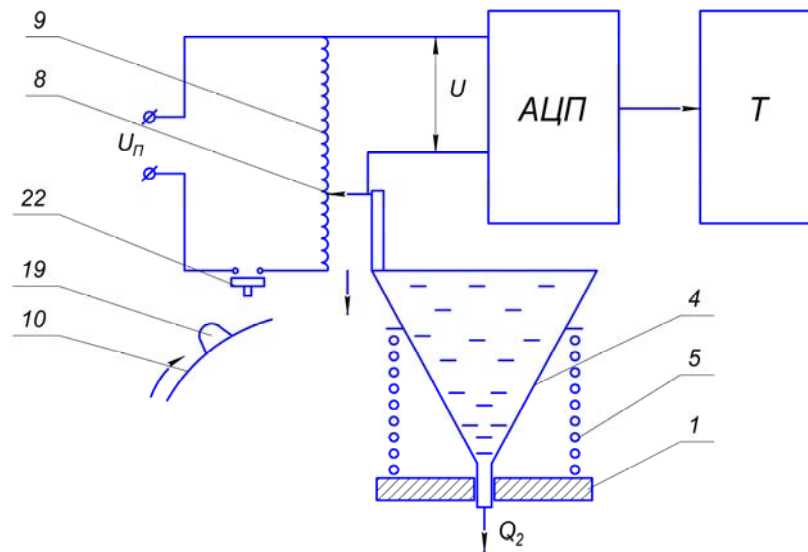

Figure 2 – Converting the funnel’s drilling mud weight signal into digital form of the drilling mud density:
ADC – Analogue digital converter ; T – demonstration panel.

Given the assigned volume of the funnel, the voltage U is corresponding to the drilling mud density. The voltage U is delivered to the ADC inlet, where it is converted to the digital number. That number is converted into decimal system and, in the density units, registers in the memory and finally appears on the driller’s panel T . There it replaces the result of the measurement, obtained in the course of the previous measurement cycle.

Meanwhile the table, continuing its revolution, again approaches the wash-up position and makes a halt there. The measurement cycle is completed and the new one commenced.

Discussion. The drilling mud quality parameters, its density in particular, are in the course of drilling subjected to spontaneous alterations with risks of down-the-hole problems and failures. Transition from the sporadic manual measurements to continuous automatic monitoring will provide for maintenance of the optimum drilling technology and failure prevention by promptly reacting on environment changes. That will amount to substantial contribution to bringing down the well construction time and expenditures on the failures elimination. Besides it will guarantee savings on salaries of the high qualified personal, conducting manual measurements.

As a result of research performed, a universal method of automatic continuous monitoring of drilling muds parameters in general and its density in particular is worked out. The problem is solved by way of automatization of the classical manual measurements. The attempts at automatization of drilling mud parameters measuring by application of various physical phenomena were not enough successful, because they are imposing various restrictions on the mud’s composition, quantity and quality of additives, viscosity, pressure in the line, temperature etc. Automatization of the classical manual measurements preserves all of its peculiar wide range of suitable conditions. It well corresponds with existing drilling technology. On the other hand the method in question well corresponds with the modern trend of transition to the digital form of data processing and presentation.

The worked out structural scheme of automatic density monitoring can become a base for developing a line of automatic measurement of other drilling mud parameters and thus contribute to solution of the problem as a whole. Incidentally, patents for structural schemes of automatic measurement of the mud’s funnel viscosity, jell strength and filtration are already obtained. The revolving tables of several appliances can be assembled on common axle and have common systems of mud samples delivery, electric power and cleaning water supply. Their measurement signals can be received by the same computer for the further processing. All that will contribute to the costs reduction.

However the complexity of such automatic facilities and the effort and resources needed for their development are substantially different, which requires the works being performed step-by-step, beginning from the simplest version, such as density and proceeding to more complex ones.

The proposed facilities can be operated at all the rigs engaged in drilling wells for oil, gas, water and hard mineral resources. They may play an important role in down-the-hole failures preventing and saving time and resources on their elimination. Besides, falls away need in employment of the highly trained personal, currently occupied in carrying out drilling mud parameters manual measurements.

Conclusions.

1. The publications studies allowed to ascertain absence of universally applicable works on drilling mud parameters automatic continuous monitoring.

2. An assumption was set forward and substantiated, that the most appropriate method of achieving the purpose of drilling mud parameters automatic continuous monitoring, is automatization of the universally used classical manual method.

3. A general scheme of the drilling mud parameters manual measurements automatization by using the revolving table is put forward.

4. According to the general sceme a structural scheme of the appliance for drilling mud density automatic continuous monitoring is elaborated.

М. Т. Билецкий¹, Ю. А. Нифонтов², Б. Т. Ратов³, Д. Н. Деликешева¹

¹Қ. И. Сәтбаев атындағы Қазақ ұлттық техникалық зерттеу университеті, Алматы, Қазақстан,

²Санкт-Петербург мемлекеттік теңіз техникалық университеті, Ресей,

³Каспий қоғамдық университеті, Алматы, Қазақстан

БУРҒЫЛАУ ЕРІТІНДІСІНІҢ ПАРАМЕТРЛЕРІН ҮЗДІКСІЗ БАҚЛАУ ПРОБЛЕМАЛАРЫ ЖӘНЕ ОНЫ ШЕШУ МЫСАЛ РЕТІНДЕ ТЫҒЫЗДЫҚТЫ АВТОМАТТЫ ТҮРДЕ ӨЛШЕУ

Аннотация. Бұрғылау ерітінділерінің сапа параметрлері бұрғылаудың геологиялық-техникалық жағдайларына сай келмеуі, көп жағдайда, бұрғылау кезіндегі қиыншылықтар мен апаттардың себебі болып келеді. Бұл параметрлер қолмен және ұзақ уақыт аралығында өлшенеді. Бұрғылау ерітінділерінің тығыздығын әртүрлі физикалық құбылыстарға негізделген датчиктер көмегімен автоматты түрде өлшеу сәтті нәтиже көрсетпеді. Бұл бұрғылау ерітінділерінің сапа құрамы мен қасиеттерінің өте алуан түрлі болуымен шартталған. Жылдар бойы қолмен өлшеу өздігінен бұрғылау жұмыстарының ерекшеліктеріне сай келеді. Дәстүрлі қолмен өлшеуді автоматтандыру оларды алдын-ала белгіленген жиілікте орындауға мүмкіндік береді және арнайы қызметкерлердің қажеттілігін жояды. Мәселе белгілі өлшеу құралдарын айналмалы үстелге орнату арқылы шешіледі. Электр өлшеу сигналы бұрғылаушының қашықтықтан басқару пультінің есеп тақтасында көрсету, сондай-ақ уақытты жазу мүмкіндігімен цифрланады. Тығыздықты автоматты бақылау геологиялық асқынулармен және апаттармен күресу шығындарын төмендетеді. Жобаланған құрылғылар барлық бұрғылау қондырғыларында, мұнай, газ, су және қатты пайдалы қазбаларға бұрғылау үшін қолданылуы мүмкін.

Түйін сөздер: бұрғылау, геологиялық асқынуларды бақылау, бұрғылау ерітінділерінің параметрлері, өлшеуді автоматтандыру, бұрғылау қондырғысында көрсету, тығыздықты автоматты өлшеуіш.

М. Т. Билецкий¹, Ю. А. Нифонтов², Б. Т. Ратов³, Д. Н. Деликешева¹

¹Казахский национальный исследовательский технический университет им. К. И. Сатпаева, Алматы, Казахстан,

²Санкт-Петербургский государственный морской технический университет, Россия,

³Каспийский общественный университет, Алматы, Казахстан

ПРОБЛЕМА НЕПРЕРЫВНОГО МОНИТОРИНГА ПАРАМЕТРОВ БУРОВОГО РАСТВОРА И ЕЕ РЕШЕНИЕ НА ПРИМЕРЕ АВТОМАТИЧЕСКОГО ИЗМЕРИТЕЛЯ ПЛОТНОСТИ

Аннотация. Причиной осложнений и аварий при бурении чаще всего является несоответствие качественных параметров буровых растворов геолого-техническим условиям бурения. Эти параметры измеряются вручную и через длительные интервалы времени. Попытки автоматического измерения плотности буровых растворов с помощью датчиков, основанных на использовании различных физических явлений, не дали успешного результата. Это обусловлено весьма широким разнообразием качественного состава и свойств буровых растворов. Годы применения ручных измерений подтверждают, что, сами по себе, они наилучшим образом отвечают специфике буровых работ. Автоматизация традиционных ручных измерений позволяет

производить их с заданной периодичностью и устраняет необходимость в специальном персонале. Задача решена путем установки известных измерительных средств на поворотном столе. Электрический измерительный сигнал преобразуется в цифровую форму с возможностью демонстрации на табло пульта бурильщика, а также регистрации во времени. Автоматический мониторинг плотности позволяет сократить расходы на борьбу с геологическими осложнениями и авариями. Разработанные устройства могут применяться на всех буровых установках, ведущих бурение на нефть, газ, воду и твердые полезные ископаемые.

Ключевые слова: бурение, борьба с геологическими осложнениями, параметры буровых растворов, автоматизация измерений, демонстрация на пульте бурильщика, автоматический измеритель плотности.

Information about authors:

Biletsky M., NAO Kazakh National Research Technical University named after K. I. Satpayev, Almaty, Kazakhstan; biletskymarc@yandex.ru; <https://orcid.org/0000-0002-4947-5686>

Nifontov Iu., Saint-Petersburg State Marine Technical University, Saint-Petersburg, Russia; nifontovy@yandex.ru; <https://orcid.org/0000-0002-0525-3731>

Ratov B., Caspian Public University, Almaty, Kazakhstan.; ratov.bt@gmail.com; <https://orcid.org/0000-0003-4707-3322>

Deliskesheva D., NAO Kazakh National Research Technical University named after K. I. Satpayev, Almaty, Kazakhstan; delikeshiva@mail.ru; <https://orcid.org/0000-0001-5442-4763>

REFERENCES

- [1] Gray G.R., Darley H.C.. Composition and properties of oil well drilling fluids. M.: Nedra, 1985. P. 53-54, 07-100.
- [2] Drilling rigs. Norwegian institute of technological standards. N-0306, Oslo, July 1998.
- [3] Pustivoitenko I.P., Selivaschuk A.P. The manual of the master on complex operations in drilling. M.: Nedra, 1983. P. 74-82.
- [4] Shach C.N. and others. The future challenges in the area of the drilling fluids and their rheological measurements. American association of drilling engineers. AADE-10-DF-HO-41, 2010.
- [5] Bilezki M.T., Ratov B.T., Kasenov A.K. The problem analysis on drilling geotechnological wells under complex conditions // Scientific and technological challenges at drilling wells. Drilling progress. IOP Conf. Section: Earth and Ecology. Science 24 (2015). 012026 IOP Publishers.
- [6] Doremus E.G. E21B49/005. Testing the well bore and formation characteristics by the data of drilling mud and cuttings. US3409092A US Grant.
- [7] Bilezki M.T., Ratov B.T., Kasenov A.K. Caving prophylaxis while drilling the highly dispersible clays on Kazakhstan's uranium fields // 15-th International Multi Discipline Scientific Geoconference SGEM2015. P. 157-164.
- [8] Reiber F. E21B21/8. Monitoring the pressure and the flow rate of drilling fluid at the example of automatic replenishment in the well bore; automatic control of the down-the-hole pressure. US6257354(B1) US Grant.
- [9] Satpajev NRTU. Report on the project: "Developing the geotechnological wells construction technology under complex conditions of the Khorasan deposit". 2009.
- [10] Drilling master's reference book. M.: Infra Enginaria, 2006. Vol. 1. P. 358-418.
- [11] Spelta at al. Real time monitoring system improves drilling efficiencies // The 13-th Ofsore Mediterranean Conference. Ravenna, 2017.
- [12] Dahlem A. Automatic djustement of drilling fluid properties. Petroleum engineering. 2013.
- [13] Mullins M.P. Automatic device for measurement of the mud properties in the drilled shafts. University of the South Florida. Thesis. 2016
- [14] Saasen A. at al. Automatic measuring the properties of drilling fluids and cuttings. SPE Well drilling and finishing. December 2009.
- [15] Carlsen A et al. Using instrumental stand pipe for monitoring automated drilling operations. Workshop on automatic control of offshore oil and gas production 2012.
- [16] Isakovich R.J. Control and automatization of oil and gas production. M.: Nedra: 1985. P. 269-270.
- [17] Bilezki M.T at al. An appliance for combined measuring the drilling mud density and cuttings content therein. Kazakhstan Republic's patent #31786, of 30.12.2016.
- [18] Biletsky M.T., Ratov B.T., Kozhevnykov A.A., Baiboz A.R., Delikesheva D.N. (2018) Updating the theoretic model of rock destruction in the course of drilling // News of the National academy of sciences of the Republic of Kazakhstan. Series of geology and technical sciences. Vol. 2, N 428 (2018). P. 63-71. ISSN 2518-170X (Online), ISSN 2224-5278 (Print).
- [19] Sudakov A., Dreus A., Ratov B., Delikesheva D. (2018) Theoretical bases of isolation technology for swallowing horizons using thermoplastic materials // News of the National academy of sciences of the Republic of Kazakhstan. Series of geology and technical sciences. Vol. 2, N 428 (2018). P. 72-80. ISSN 2518-170X (Online), ISSN 2224-5278 (Print).
- [20] Burachek V., Malik T., Kryachok S., Bryk Y., Belenok V. (2018) Device for automated leveling // News of the National academy of sciences of the Republic of Kazakhstan. Series of geology and technical sciences. Vol. 5, N 431 (2018). P. 95-99. <https://doi.org/10.32014/2018.2518-170X.13> ISSN 2518-170X (Online), ISSN 2224-5278 (Print).
- [21] Rakishev B.R., Shashenko A.N., Kovrov A.S. (2018) Trends of therock failure conceptions development // News of the National academy of sciences of the Republic of Kazakhstan. Series of geology and technical sciences. Vol. 5, N 431 (2018). P. 161-169. <https://doi.org/10.32014/2018.2518-170X.46> ISSN 2518-170X (Online), ISSN 2224-5278 (Print).

**Publication Ethics and Publication Malpractice
in the journals of the National Academy of Sciences of the Republic of Kazakhstan**

For information on Ethics in publishing and Ethical guidelines for journal publication see <http://www.elsevier.com/publishingethics> and <http://www.elsevier.com/journal-authors/ethics>.

Submission of an article to the National Academy of Sciences of the Republic of Kazakhstan implies that the described work has not been published previously (except in the form of an abstract or as part of a published lecture or academic thesis or as an electronic preprint, see <http://www.elsevier.com/postingpolicy>), that it is not under consideration for publication elsewhere, that its publication is approved by all authors and tacitly or explicitly by the responsible authorities where the work was carried out, and that, if accepted, it will not be published elsewhere in the same form, in English or in any other language, including electronically without the written consent of the copyright-holder. In particular, translations into English of papers already published in another language are not accepted.

No other forms of scientific misconduct are allowed, such as plagiarism, falsification, fraudulent data, incorrect interpretation of other works, incorrect citations, etc. The National Academy of Sciences of the Republic of Kazakhstan follows the Code of Conduct of the Committee on Publication Ethics (COPE), and follows the COPE Flowcharts for Resolving Cases of Suspected Misconduct (http://publicationethics.org/files/u2/New_Code.pdf). To verify originality, your article may be checked by the Cross Check originality detection service <http://www.elsevier.com/editors/plagdetect>.

The authors are obliged to participate in peer review process and be ready to provide corrections, clarifications, retractions and apologies when needed. All authors of a paper should have significantly contributed to the research.

The reviewers should provide objective judgments and should point out relevant published works which are not yet cited. Reviewed articles should be treated confidentially. The reviewers will be chosen in such a way that there is no conflict of interests with respect to the research, the authors and/or the research funders.

The editors have complete responsibility and authority to reject or accept a paper, and they will only accept a paper when reasonably certain. They will preserve anonymity of reviewers and promote publication of corrections, clarifications, retractions and apologies when needed. The acceptance of a paper automatically implies the copyright transfer to the National Academy of Sciences of the Republic of Kazakhstan.

The Editorial Board of the National Academy of Sciences of the Republic of Kazakhstan will monitor and safeguard publishing ethics.

Правила оформления статьи для публикации в журнале смотреть на сайте:

[www:nauka-nanrk.kz](http://www.nauka-nanrk.kz)

ISSN 2518-170X (Online), ISSN 2224-5278 (Print)

<http://www.geolog-technical.kz/index.php/en/>

Верстка Д. Н. Калкабековой

Подписано в печать 15.11.2019.

Формат 70x881/8. Бумага офсетная. Печать – ризограф.

19,7 п.л. Тираж 300. Заказ 6.