

ISSN 2518-170X (Online),  
ISSN 2224-5278 (Print)

ҚАЗАҚСТАН РЕСПУБЛИКАСЫ  
ҰЛТТЫҚ ҒЫЛЫМ АКАДЕМИЯСЫНЫҢ  
Satbayev University

# Х А Б А Р Л А Р Ы

---

---

## ИЗВЕСТИЯ

НАЦИОНАЛЬНОЙ АКАДЕМИИ НАУК  
РЕСПУБЛИКИ КАЗАХСТАН  
Satbayev University

## NEWS

OF THE ACADEMY OF SCIENCES  
OF THE REPUBLIC OF KAZAKHSTAN  
Satbayev University

**SERIES  
OF GEOLOGY AND TECHNICAL SCIENCES**

**3 (441)**

**MAY – JUNE 2020**

THE JOURNAL WAS FOUNDED IN 1940

PUBLISHED 6 TIMES A YEAR

ALMATY, NAS RK

---

*NAS RK is pleased to announce that News of NAS RK. Series of geology and technical sciences scientific journal has been accepted for indexing in the Emerging Sources Citation Index, a new edition of Web of Science. Content in this index is under consideration by Clarivate Analytics to be accepted in the Science Citation Index Expanded, the Social Sciences Citation Index, and the Arts & Humanities Citation Index. The quality and depth of content Web of Science offers to researchers, authors, publishers, and institutions sets it apart from other research databases. The inclusion of News of NAS RK. Series of geology and technical sciences in the Emerging Sources Citation Index demonstrates our dedication to providing the most relevant and influential content of geology and engineering sciences to our community.*

*Қазақстан Республикасы Ұлттық ғылым академиясы "ҚР ҰҒА Хабарлары. Геология және техникалық ғылымдар сериясы" ғылыми журналының Web of Science-тің жаңаланған нұсқасы Emerging Sources Citation Index-те индекстелуге қабылданғанын хабарлайды. Бұл индекстелу барысында Clarivate Analytics компаниясы журналды одан әрі the Science Citation Index Expanded, the Social Sciences Citation Index және the Arts & Humanities Citation Index-ке қабылдау мәселесін қарастыруда. Web of Science зерттеушілер, авторлар, баспашылар мен мекемелерге контент тереңдігі мен сапасын ұсынады. ҚР ҰҒА Хабарлары. Геология және техникалық ғылымдар сериясы Emerging Sources Citation Index-ке енуі біздің қоғамдастық үшін ең өзекті және беделді геология және техникалық ғылымдар бойынша контентке адалдығымызды білдіреді.*

*НАН РК сообщает, что научный журнал «Известия НАН РК. Серия геологии и технических наук» был принят для индексирования в Emerging Sources Citation Index, обновленной версии Web of Science. Содержание в этом индексировании находится в стадии рассмотрения компанией Clarivate Analytics для дальнейшего принятия журнала в the Science Citation Index Expanded, the Social Sciences Citation Index и the Arts & Humanities Citation Index. Web of Science предлагает качество и глубину контента для исследователей, авторов, издателей и учреждений. Включение Известия НАН РК. Серия геологии и технических наук в Emerging Sources Citation Index демонстрирует нашу приверженность к наиболее актуальному и влиятельному контенту по геологии и техническим наукам для нашего сообщества.*

Б а с р е д а к т о р ы  
э. ғ. д., профессор, ҚР ҰҒА академигі

**И.К. Бейсембетов**

Бас редакторының орынбасары

**Жолтаев Г.Ж.** проф., геол.-мин. ғ. докторы

Р е д а к ц и я а л қ а с ы:

**Абаканов Т.Д.** проф. (Қазақстан)  
**Абишева З.С.** проф., академик (Қазақстан)  
**Агабеков В.Е.** академик (Беларусь)  
**Алиев Т.** проф., академик (Әзірбайжан)  
**Бакиров А.Б.** проф., (Қырғызстан)  
**Беспәев Х.А.** проф. (Қазақстан)  
**Бишимбаев В.К.** проф., академик (Қазақстан)  
**Буктуков Н.С.** проф., академик (Қазақстан)  
**Булат А.Ф.** проф., академик (Украина)  
**Ганиев И.Н.** проф., академик (Тәжікстан)  
**Грэвис Р.М.** проф. (АҚШ)  
**Ерғалиев Г.К.** проф., академик (Қазақстан)  
**Жуков Н.М.** проф. (Қазақстан)  
**Қожахметов С.М.** проф., академик (Қазақстан)  
**Конторович А.Э.** проф., академик (Ресей)  
**Курскеев А.К.** проф., академик (Қазақстан)  
**Курчавов А.М.** проф., (Ресей)  
**Медеу А.Р.** проф., академик (Қазақстан)  
**Мұхамеджанов М.А.** проф., корр.-мүшесі (Қазақстан)  
**Нигматова С.А.** проф. (Қазақстан)  
**Оздоев С.М.** проф., академик (Қазақстан)  
**Постолатий В.** проф., академик (Молдова)  
**Ракишев Б.Р.** проф., академик (Қазақстан)  
**Сейтов Н.С.** проф., корр.-мүшесі (Қазақстан)  
**Сейтмуратова Э.Ю.** проф., корр.-мүшесі (Қазақстан)  
**Степанец В.Г.** проф., (Германия)  
**Хамфери Дж.Д.** проф. (АҚШ)  
**Штейнер М.** проф. (Германия)

«ҚР ҰҒА Хабарлары. Геология және техникалық ғылымдар сериясы».

**ISSN 2518-170X (Online),**

**ISSN 2224-5278 (Print)**

Меншіктенуші: «Қазақстан Республикасының Ұлттық ғылым академиясы» РҚБ (Алматы қ.).

Қазақстан республикасының Мәдениет пен ақпарат министрлігінің Ақпарат және мұрағат комитетінде  
30.04.2010 ж. берілген №10892-Ж мерзімдік басылым тіркеуіне қойылу туралы куәлік.

Мерзімділігі: жылына 6 рет.

Тиражы: 300 дана.

Редакцияның мекенжайы: 050010, Алматы қ., Шевченко көш., 28, 219 бөл., 220, тел.: 272-13-19, 272-13-18,  
<http://www.geolog-technical.kz/index.php/en/>

---

© Қазақстан Республикасының Ұлттық ғылым академиясы, 2020

Редакцияның Қазақстан, 050010, Алматы қ., Қабанбай батыр көш., 69а.

мекенжайы: Қ. И. Сәтбаев атындағы геология ғылымдар институты, 334 бөлме. Тел.: 291-59-38.

Типографияның мекенжайы: «NurNaz GRACE», Алматы қ., Рысқұлов көш., 103.

Г л а в н ы й р е д а к т о р  
д. э. н., профессор, академик НАН РК

**И. К. Бейсембетов**

Заместитель главного редактора

**Жолтаев Г.Ж.** проф., доктор геол.-мин. наук

Р е д а к ц и о н н а я к о л л е г и я:

**Абаканов Т.Д.** проф. (Казахстан)  
**Абишева З.С.** проф., академик (Казахстан)  
**Агабеков В.Е.** академик (Беларусь)  
**Алиев Т.** проф., академик (Азербайджан)  
**Бакиров А.Б.** проф., (Кыргызстан)  
**Беспаяев Х.А.** проф. (Казахстан)  
**Бишимбаев В.К.** проф., академик (Казахстан)  
**Буктуков Н.С.** проф., академик (Казахстан)  
**Булат А.Ф.** проф., академик (Украина)  
**Ганиев И.Н.** проф., академик (Таджикистан)  
**Грэвис Р.М.** проф. (США)  
**Ергалиев Г.К.** проф., академик (Казахстан)  
**Жуков Н.М.** проф. (Казахстан)  
**Кожаметов С.М.** проф., академик (Казахстан)  
**Конторович А.Э.** проф., академик (Россия)  
**Курскеев А.К.** проф., академик (Казахстан)  
**Курчавов А.М.** проф., (Россия)  
**Медеу А.Р.** проф., академик (Казахстан)  
**Мухамеджанов М.А.** проф., чл.-корр. (Казахстан)  
**Нигматова С.А.** проф. (Казахстан)  
**Оздоев С.М.** проф., академик (Казахстан)  
**Постолатий В.** проф., академик (Молдова)  
**Ракишев Б.Р.** проф., академик (Казахстан)  
**Сейтов Н.С.** проф., чл.-корр. (Казахстан)  
**Сейтмуратова Э.Ю.** проф., чл.-корр. (Казахстан)  
**Степанец В.Г.** проф., (Германия)  
**Хамфери Дж.Д.** проф. (США)  
**Штейнер М.** проф. (Германия)

«Известия НАН РК. Серия геологии и технических наук».

**ISSN 2518-170X (Online),**

**ISSN 2224-5278 (Print)**

Собственник: Республиканское общественное объединение «Национальная академия наук Республики Казахстан (г. Алматы).

Свидетельство о постановке на учет периодического печатного издания в Комитете информации и архивов Министерства культуры и информации Республики Казахстан №10892-Ж, выданное 30.04.2010 г.

Периодичность: 6 раз в год.

Тираж: 300 экземпляров.

Адрес редакции: 050010, г. Алматы, ул. Шевченко, 28, ком. 219, 220, тел.: 272-13-19, 272-13-18,  
<http://www.geolog-technical.kz/index.php/en/>

---

© Национальная академия наук Республики Казахстан, 2020

Адрес редакции: Казахстан, 050010, г. Алматы, ул. Кабанбай батыра, 69а.

Институт геологических наук им. К. И. Сатпаева, комната 334. Тел.: 291-59-38.

Адрес типографии: «NurNaz GRACE», г. Алматы, ул. Рыскулова, 103.

E d i t o r i n c h i e f

doctor of Economics, professor, academician of NAS RK

**I. K. Beisembetov**

Deputy editor in chief

**Zholtayev G.Zh.** prof., dr. geol-min. sc.

E d i t o r i a l b o a r d:

**Abakanov T.D.** prof. (Kazakhstan)  
**Abisheva Z.S.** prof., academician (Kazakhstan)  
**Agabekov V.Ye.** academician (Belarus)  
**Aliyev T.** prof., academician (Azerbaijan)  
**Bakirov A.B.** prof., (Kyrgyzstan)  
**Bespayev Kh.A.** prof. (Kazakhstan)  
**Bishimbayev V.K.** prof., academician (Kazakhstan)  
**Buktukov N.S.** prof., academician (Kazakhstan)  
**Bulat A.F.** prof., academician (Ukraine)  
**Ganiyev I.N.** prof., academician (Tadjikistan)  
**Gravis R.M.** prof. (USA)  
**Yergaliev G.K.** prof., academician (Kazakhstan)  
**Zhukov N.M.** prof. (Kazakhstan)  
**Kozhakhmetov S.M.** prof., academician (Kazakhstan)  
**Kontorovich A.Ye.** prof., academician (Russia)  
**Kurskeyev A.K.** prof., academician (Kazakhstan)  
**Kurchavov A.M.** prof., (Russia)  
**Medeu A.R.** prof., academician (Kazakhstan)  
**Muhamedzhanov M.A.** prof., corr. member. (Kazakhstan)  
**Nigmatova S.A.** prof. (Kazakhstan)  
**Ozdoyev S.M.** prof., academician (Kazakhstan)  
**Postolatii V.** prof., academician (Moldova)  
**Rakishev B.R.** prof., academician (Kazakhstan)  
**Seitov N.S.** prof., corr. member. (Kazakhstan)  
**Seitmuratova Ye.U.** prof., corr. member. (Kazakhstan)  
**Stepanets V.G.** prof., (Germany)  
**Humphery G.D.** prof. (USA)  
**Steiner M.** prof. (Germany)

**News of the National Academy of Sciences of the Republic of Kazakhstan. Series of geology and technology sciences.**

**ISSN 2518-170X (Online),**

**ISSN 2224-5278 (Print)**

Owner: RPA "National Academy of Sciences of the Republic of Kazakhstan" (Almaty).

The certificate of registration of a periodic printed publication in the Committee of information and archives of the Ministry of culture and information of the Republic of Kazakhstan N 10892-Ж, issued 30.04.2010.

Periodicity: 6 times a year.

Circulation: 300 copies.

Editorial address: 28, Shevchenko str., of. 219, 220, Almaty, 050010, tel. 272-13-19, 272-13-18,

<http://www.geolog-technical.kz/index.php/en/>

---

© National Academy of Sciences of the Republic of Kazakhstan, 2020

Editorial address: Institute of Geological Sciences named after K.I. Satpayev

69a, Kabanbai batyr str., of. 334, Almaty, 050010, Kazakhstan, tel.: 291-59-38.

Address of printing house: «NurNaz GRACE», 103, Ryskulov str, Almaty.

**NEWS**

OF THE NATIONAL ACADEMY OF SCIENCES OF THE REPUBLIC OF KAZAKHSTAN

**SERIES OF GEOLOGY AND TECHNICAL SCIENCES**

ISSN 2224-5278

Volume 3, Number 441 (2020), 151 – 160

<https://doi.org/10.32014/2020.2518-170X.66>

UDC 621.372.632:621.365.5

**N. T. Isembergenov<sup>1</sup>, A. Zh. Sagyndikova<sup>2</sup>, P. Daskalov<sup>3</sup>**<sup>1</sup>Satbayev University, Almaty, Kazakhstan;<sup>2</sup>Gumarbek Daukeev Almaty University of Energy and Communications, Almaty, Kazakhstan;<sup>3</sup>University of Ruse Angel Kanchev UR · Department of Automation and Mechatronics, Ruse, Bulgaria.

E-mail: isembergenov@mail.ru, sagyndikova\_aigul@mail.ru

**DEVELOPMENT AND RESEARCH OF A FREQUENCY  
CONVERTER WITH INTELLIGENT CONTROL  
SYSTEM WITH INDUCTION HEATER**

**Abstract.** The article has a frequency converter for induction heating of metal. Induction heating is a technology with low cost, high efficiency, low weight and dimensions, it provides a wide range of frequency control of the converter, the choice of the minimum number of power transistors, the establishment of the minimum power. Experienced frequency and inductance converters for metal and wort are designed and manufactured in the work. Experimental studies and tests of a prototype frequency converter were carried out. The issues of using the developed models and methods for controlling induction heating are considered.

Frequency converters are known where transformers are used to reduce voltages. The task is to create such a frequency converter, where the number of transistor modules would be minimum, and the step-down transformer would have the lowest overall dimensions.

An experimental model of a frequency converter and inductor with a power of 6 kW with a frequency of 2 to 20 kHz was developed and manufactured with power supply from one or three-phase voltage. Experimental studies and tests of a prototype frequency converter for induction heating of metal in real conditions were carried out.

In the development of technical documentation for the manufacture of a laboratory sample of the frequency converter and the selection of transistor JGBT modules, the main attention was paid to the topology of the power buses of the module and how to connect electrical circuits and remove heat. Even with the most advanced chips, the design of powerful key modules is extremely important to ensure reliability and efficiency. Distributed conductivity characteristics and parasitic inductance values of communication buses and terminals should have a minimum value to reduce losses and reduce the level of transient overvoltages.

For a more complete analysis, modeling was performed in the environment of MatLab R12 v.6.0, this package is intended for solving mathematical calculations of any complexity, for professional analysis and modeling of processes in electrical and electronic circuits, static processing of measurement results and experiments, as well as building Charts. In the simulation we used the Simulink Library Browzers library, as well as SimPowerSystems.

**Key words:** frequency converters, induction heater, transistor module, triacs, three-phase rectifier, inverter.

**Introduction.** Frequency converters (FC) for induction heating of metal consist of IGBT or MOSFET transistor modules connected in a specific configuration with control drivers. At the same time, they have protection against short circuit currents, overloads and protection against excessive temperatures. Currently, the use of inverters for induction heating of metal in the industry of Kazakhstan is practically absent, since the unit cost of existing foreign analogues is very high, so their mass introduction is unprofitable. You should develop your technology with low cost, high efficiency, low weight and size.

Frequency converters can be used in the following technologies:

- for induction heating of metals for stamping,
- for melting metals in induction melting crucible furnaces,
- for induction heating of metals for the purpose of hot volume hardening,
- for induction heating of oil in pipelines and tanks,

- for induction drying of grain, heating of liquid media, drying of wood and coatings and the production of milk powder [1,3,7,12].

The main objectives and goals are to create an inverter production technology, which should: provide the required frequency control range for the inverter, select the minimum number of power transistors, have high efficiency and low prices, minimum installed power of the entire inverter or its individual elements with the same given parameters of heating technology.

**Research of a frequency converter with an intelligent control system with an induction heater.**

Frequency converters are known where transformers are used to reduce voltages. The task is to create such a frequency converter, where the number of transistor modules would be minimum, and the step-down transformer would have the lowest overall dimensions. The electrical circuit of a frequency converter on two transistors with a single-phase power supply for an induction heater is shown in figure 1, consisting of blocks: a block 1-input triacs, a block 2-three-phase rectifier, a block 3-inverter [5,6].

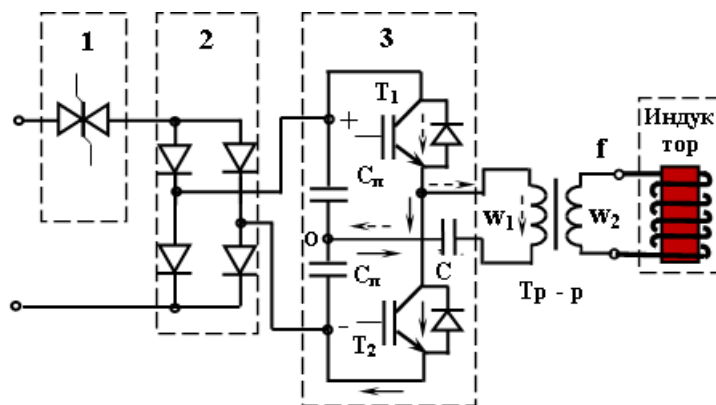

Figure 1 – The electrical circuit of the frequency converter of the induction heater with single-phase power

A feature of the inverter is that it is made on two transistors. The inverter direct voltage is converted to alternating voltage of high intermediate frequency  $f_{\text{и}}$  (figure 1). Further, from the moment of time  $t = 0$ , one of the two thyristors T-p1 opens, and the rectified one-half-voltage of a given frequency  $f_{\text{и}}$  falls into the load, and at the time  $t = T / 2$  the first thyristor T-p1 closes.

To form a negative half-wave of the output voltage from the time  $t = T / 2$  to  $t = T$ , the second thyristor T-p2 opens, and the rectified voltage of high intermediate frequency gets into the load and at the time  $t = T$  the thyristor T- P2 closes. This forms a negative half-wave of the output voltage. The thyristor control unit in the time interval  $t = 0 - T$  will adjust the frequency of the voltage at the load to the desired value [1,7].

Thus, the voltage at the output of the transformerless inverter has the form of a rectified sinusoid, consisting of single-period rectified high-frequency voltages and this frequency of the voltage at the load will be equal to

$$f = \frac{f_{\text{и}}}{n}, \tag{1}$$

where  $f_{\text{и}}$ - is the intermediate frequency at the inverter output,  $n$  is the number of rectified voltage periods of the intermediate frequency.

As can be seen from the last expression, the formation of voltage on a given load occurs from rectified high-frequency voltages.

For example, with an intermediate frequency at the inverter output  $f_{\text{и}} = 20,000$  Hz and with the number of straightened periods  $n = 40$ , the frequency of the voltage at the load will be

$$f = \frac{f_{\text{и}}}{n} = \frac{20000}{40} = 500 \text{ Hz.} \tag{2}$$

Figure 2 shows the electric circuit of the frequency converter of the induction heater with three-phase power supply. The three-phase rectifier of block 2 is designed to convert AC voltage to DC, and the inverter converts direct current into alternating voltage of high frequency [5].

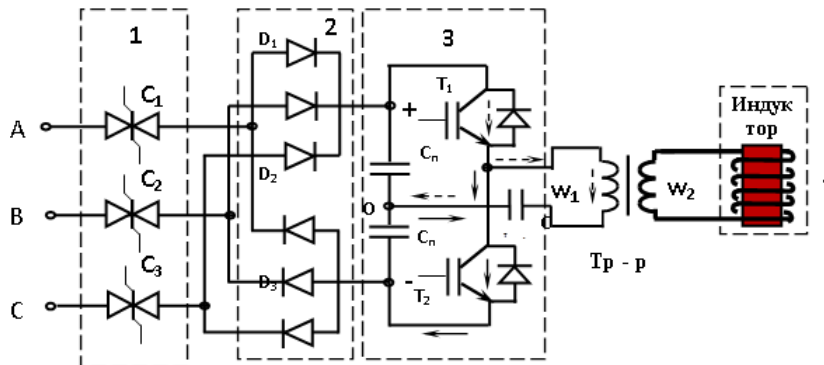

Figure 2 – Electric circuit of the frequency converter of induction heater with three-phase power supply

The inductor is designed to convert high frequency electrical energy into heat energy, and the transformer lowers the voltage to the required value. The rectifier and inverter are presented as a frequency converter. The output transformer is used to coordinate the parameters of the inductor with the workpiece with the parameters of the high-frequency inverter, while the overall dimensions of the transformer are reduced several times.

Input triacs  $C_1, C_2, C_3$  of block 1 are made not only for the non-contact inclusion of the frequency converter in the network, but also for regulating the input voltage. The fact is that during operation of the induction heater, every few minutes it is necessary to disconnect the frequency converter from the mains, since the heated metal (billet) should be removed from the inductor and transferred for stamping. Next, insert the new blank into the inductor and turn on the frequency converter in the network. The half-bridge inverter of block 3, formed on IGBT transistors  $T_1$  and  $T_2$  (figure 1), is connected to a DC voltage source, capacitors  $C_n$  (lower and upper) are designed to separate the supply voltage into two equal parts. The capacitor  $C_n$  in the inverter output circuit is made to improve the quality of the output voltage and in order to achieve a consistent resonance.

In addition, in block 3, for the formation of a positive half-period of voltage at the inverter output, the transistor  $T_1$  opens, and the transistor  $T_2$  is closed, while the constant current from the voltage source will flow through the transistor  $T_1$  and the primary winding of the transformer. To form a negative half-period at the inverter output, the transistor  $T_2$  opens, and the transistor  $T_1$  closes, and a constant current from the voltage source will flow through transistors  $T_2$  and the primary winding of the transformer in the opposite direction.

Thus, a step voltage is generated at the inverter output. It should be noted that the frequency of the step voltage on the inductor is determined by the switching frequency of transistors and can reach tens of kilohertz. This mode of operation of the inverter with a minimum number of power transistors will increase the frequency range of the current at the inductor and improve their energy performance, as well as increase reliability and reduce the cost of equipment.

The bridge circuit of a three-phase rectifier of block 2 is connected to the triac output (figure 1). As you know, the bridge circuit of a three-phase rectifier provides the least ripple output voltage. In the bridge circuit of a three-phase rectifier, uncontrolled diodes open afterwards with a shift of  $60^\circ$ , and the  $D_1, D_3$  и  $D_5$  diodes open in positive and the  $D_6, D_2$  и  $D_4$  diodes open in negative half-periods of phase stresses. The conduction interval of each diode is  $120^\circ$ , at each moment of time two diodes are open (one in the bridge arm) and the voltage across the load is determined by the phase voltage difference, i.e., whether  $\pi$ -neine voltage. The average value of the voltage at the load with a sinusoidal mains voltage has the following form,

$$U_{cp} = \frac{6\sqrt{2}}{\pi} U_m \sin \frac{\pi}{6} \cos \alpha = 1,35 U_{\pi} \cos \alpha = 2,34 U_{\phi} \cos \alpha \tag{3}$$

where  $U_{\pi} = \sqrt{3} U_{\phi}$  is the effective value of the linear voltage of the secondary winding of the transformer.



**Test results of the manufactured experimental sample of the frequency converter and inductor, data processing.** An experimental model of a frequency converter and inductor with a power of 6 kW with a frequency of 2 to 20 kHz was developed and manufactured with power supply from one or three-phase voltage. Experimental studies and tests of a prototype frequency converter for induction heating of metal in real conditions were carried out.

Figure 3 shows the process of induction heating of a metal billet with a diameter of 44 mm and a length of 80 mm. At the beginning of the induction heating process, the metal did not heat up uniformly, i.e. in the middle of the workpiece, the temperature was lower than at the edges. This meant that the penetration depth of the electromagnetic wave is not significant, so you should choose a lower current frequency, however, this will increase the heating time of the metal. The time of heating the metal with a frequency converter to a temperature of 600-6500C was 3.5 minutes at a frequency of 8 kHz and at a frequency of 10 kHz - 2.41 minutes (figure 4). At the same time, the transistors did not overheat, which is required by the operating conditions.



Figure 3 – Induction heater during the test period

The test results showed that the created induction heater was operational, passed a successful test, and the cooling system of the inductor was working properly. The process of induction heating of the metal can be carried out to the desired temperature.



Figure 4 – The process of induction heating of metal to a temperature of 731<sup>0</sup> C

In the development of technical documentation for the manufacture of a laboratory sample of the frequency converter and the selection of transistor JGBT modules, the main attention was paid to the topology of the power buses of the module and how to connect electrical circuits and remove heat. Even with the most advanced chips, the design of powerful key modules is extremely important to ensure reliability and efficiency. Distributed conductivity characteristics and parasitic inductance values of

communication buses and terminals should have a minimum value to reduce losses and reduce the level of transient overvoltages.

Figure 5, 6 shows the waveform of the voltage at the inverter output without a capacitor in the primary circuit of the transformer. As can be seen from the graph, the voltage waveform is oscillatory in nature, which means that the transistors are in active mode. In this case, they will heat up and ultimately fail. In order for the transistors to switch to the key mode, it is necessary to turn on the capacitor Cn in series in the output circuit of the inverter, improve the quality of the output voltage and achieve a consistent resonance.

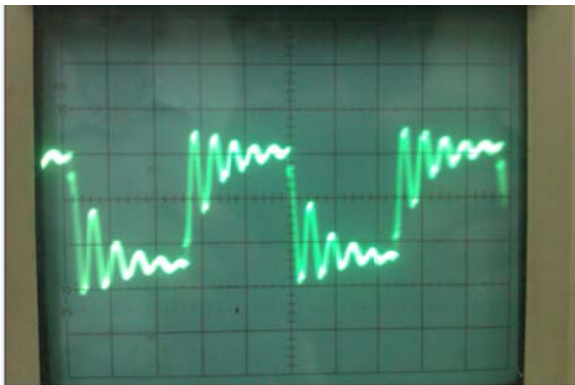

Figure 5 – Voltage waveform at inverter output without capacitor in transformer primary circuit

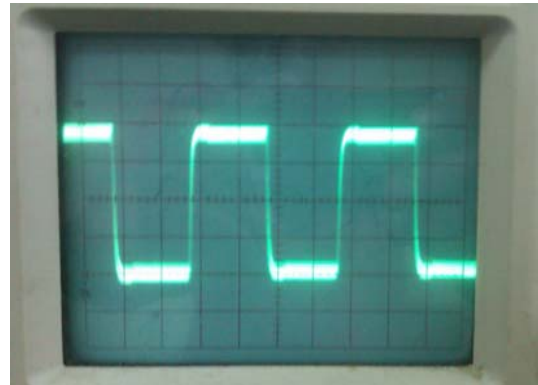

Figure 6 – Waveform of the voltage at the output of the inverter with a capacitor in the primary circuit of the transformer

Figure 6 shows the waveform of the voltage at the inverter output with a capacitor in the primary circuit of the transformer. As can be seen from the graph, the voltage at the inverter output has a rectangular shape, which means that the transistors work in key mode, while they will not heat up. In addition, by choosing experimentally the value of the capacitor Cn, it is possible not only to improve the quality of the output voltage, but to achieve a consistent resonance. At resonance, the active power of the inverter will be transferred to the inductor, i.e. blank for heating.

Induction heating of metal products is carried out using a special device called an inductor. When an alternating current is passed through an inductor, a magnetic field appears around its wire, the intensity of which periodically changes in time in magnitude and direction. The magnetic field strength, and, consequently, the magnetic flux density - induction - will be greatest inside the coil of the inductor near the wire.

If a metal cylinder is placed inside the inductor, then the alternating magnetic flux penetrating this cylinder will cause the appearance of an induced current in it. The induced current due to the proximity effect will be concentrated under the inductor wire, and its path will have an annular shape. The higher the frequency of the current, the more current flows in the cylinder in a thinner layer, i.e. the stronger the surface effect.

The main part of the inductor is an induction wire, the design of which largely determines the result of heating. The heating time of each element of the surface of the cylinder passing under the induction wire, the longer, the greater the width of the wire and the lower the speed of grain movement relative to the inductor. Therefore, the concept of heating time (formula 3) of a cylindrical surface is similar to the concept of heating time with a simultaneous heating method.

$$t_R = a/v \tag{4}$$

where  $t_R$  - is the heating time of the cylindrical surface, s;  $a$ - is the width of the induction wire, cm;  $v$ - is the speed of movement, cm / s.

The specific power on the surface of the cylinder covered by the inductor is calculated by the formula

$$p_0 = \frac{P_{\text{пч}}}{\pi D_2 a'} \tag{5}$$

where  $P_{\text{пч}}$ - is the total power of the frequency converter on the cylinder surface, kW;  $D_2$  ameter of the part, see.

For a given power of the frequency converter for induction heating, we obtain the following relation for determining the maximum width of the induction wire:

$$a = \frac{P_{\text{пч}}}{\pi D_2 \rho_0},$$

or, expressing the power of the cylinder through the power of the frequency converter, we obtain

$$a = \frac{\eta_{\text{н}} \eta_{\text{тп}} P_{\text{пч}}}{\pi D_2 a}, \quad (6)$$

where  $P_{\text{пч}}$  is the power of the frequency converter, kW;  $\eta_{\text{н}}$ - the efficiency of the inductor;  $\eta_{\text{тп}}$ - Efficiency of a step-down transformer.

On average, you can take  $\eta_{\text{н}} \approx \eta_{\text{тп}} \approx 0.8$ . Then the width of the inductor (cm) will be

$$a = \frac{0,64 P_{\text{пч}}}{\pi D_2 \rho_0},$$

or

$$a = \frac{0,2 P_{\text{пч}}}{D_2 \rho_0}, \quad (7)$$

Estimated values of the heating time and specific power depending on the depth of the heated layer, diameter and frequency can be determined.

Since at a given depth of the heated layer, the heating time is a known quantity, the inductor width can be determined by the formula

$$a = vt_{\text{к}} \quad (8)$$

In this case, the required power of the frequency converter (kW) based on the formula (8) is equal to

$$P_{\text{пч}} = 5a D_2 \rho_0 \quad (8)$$

The current induced in the surface layers of the cylinder causes it to heat, and the surface temperature and depth of heating depend on the power supplied to the inductor, the frequency and time of heating. On the other hand, the width of the heating strip, its shape and uniformity of surface heating depend on the shape of the inductor.

For example, figure 3 shows the developed transistor - thyristor frequency converter, which can be used depending on the power and productivity of grain drying. The frequency converter operates as follows. The temperature of the grain can be measured with thermometers. The remaining parts are auxiliary, and their construction usually does not cause difficulties.

The bridge circuit of the inverter formed by transistors T1, T2, T3 and T4 (figure 2) is connected to the first voltage source  $U_{\text{п}}$ . At the time  $t_1$ , transistors T1 and T4 open and direct current from the voltage source  $U_{\text{п}}$  will flow through transistors T1 and T4. This is the formation of a positive half-cycle of the stepwise voltage at the load.

To form a negative half-cycle of the stepwise voltage on the load at time  $t_1 + T / 2$ , where  $T$  is the voltage period, transistors T2 and T3 open and the direct current from  $U_{\text{п}}$  will flow through transistors T2 and T3, in the opposite direction.

Thus, the formation of a negative half-cycle of voltage and step voltage at the load. It should be noted that the frequency of the step voltage at the load is determined by the switching frequency of the transistors and can reach up to hundreds of kilohertz [11].

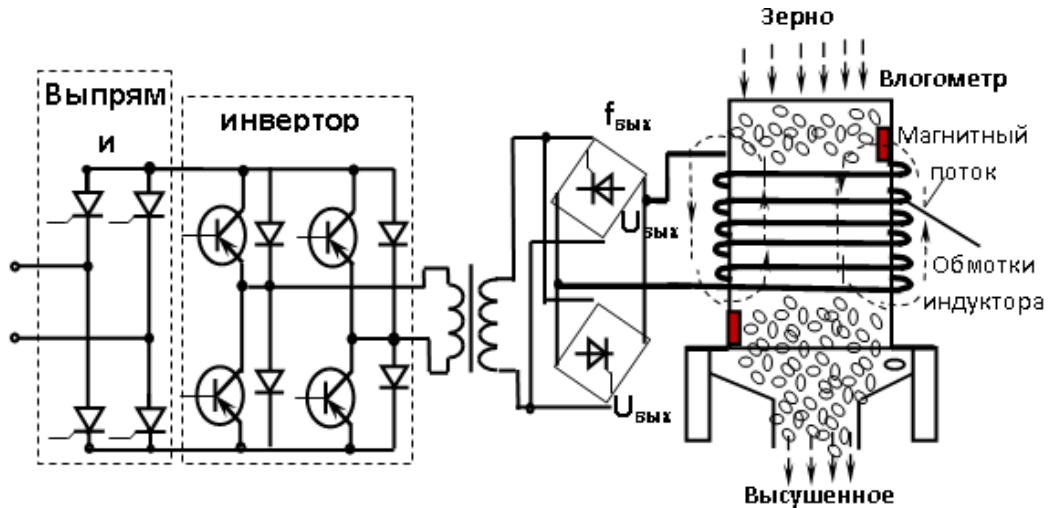

Figure 7 – Transistor-thyristor frequency converter with a higher frequency link for drying grain

Inverter direct voltage is converted into alternating voltage of high intermediate frequency  $f_{п}$  (figure 7). Then, from the moment of time  $t = 0$ , one T-p1 of two thyristor rectifiers opens, and the rectified two-half-voltage of a given frequency  $f_{out}$  falls into the load, and at the time of  $t = T / 2$ , the first thyristor rectifier T-p1 closes [16,17].

To form a negative half-wave of the output voltage from the time  $t = T / 2$  to  $t = T$ , the second thyristor rectifier T-p2 opens, and the rectified voltage of a high intermediate frequency gets into the load and at the time  $t = T$  the second thyristor rectifier T-p2 closes. This forms a negative half-wave of the output voltage. The thyristor control unit in the time interval  $t = 0 - T$  will adjust the frequency of the voltage at the load to a predetermined value. The advantage of this circuit is that the output voltage will be twice as high as in the first case (figure 7), since there is a two-half-wave voltage rectification circuit.

For a more complete analysis, modeling was performed in the environment of MatLab R12 v.6.0, this package is intended for solving mathematical calculations of any complexity, for professional analysis and modeling of processes in electrical and electronic circuits, static processing of measurement results and experiments, as well as building Charts. In the simulation we used the Simulink Library Browzers library, as well as SimPowerSystems. Figure 8 shows a simulation circuit of a transistor - thyristor inverter with a purely active load. The simulation results are shown in figure 9 with a net active load. As can be seen from the figure, with a net active load, the voltage and current in the load have a clearly defined graph. The principle of operation of a transistor - thyristor frequency converter with a half-wave voltage rectification circuit is confirmed.

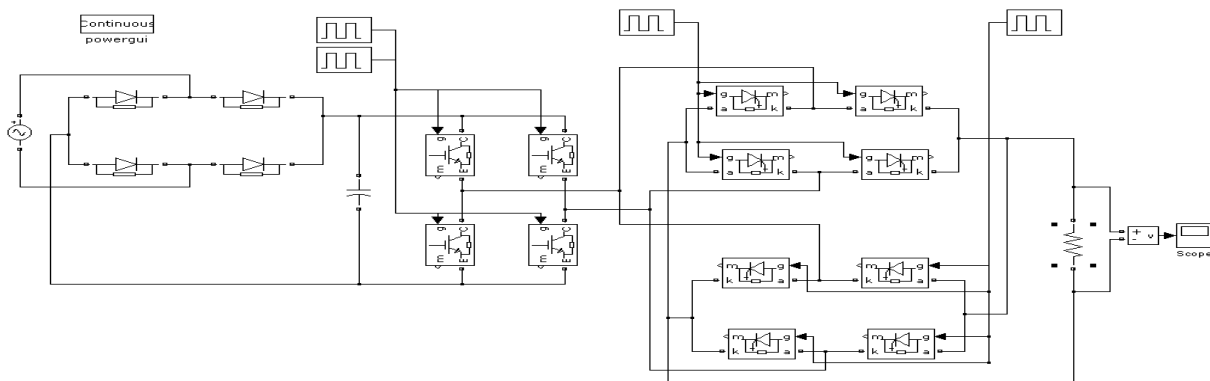

Figure 8 – Simulation scheme of transistor – thyristor frequency converter

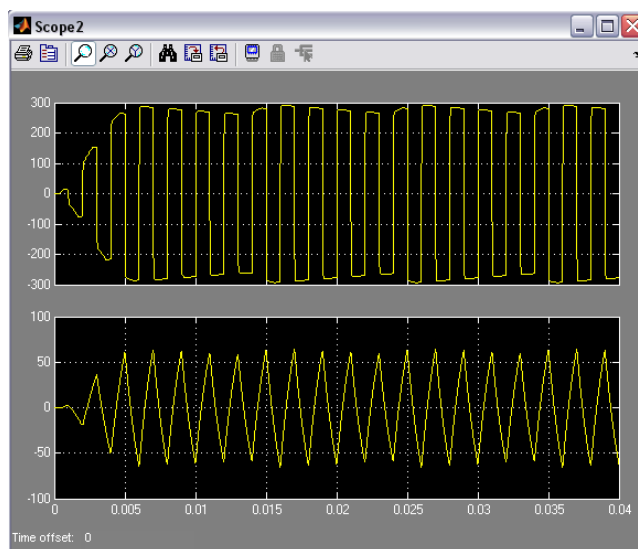

Figure 9 – Results of simulation of a frequency converter under active load

An alternating voltage was applied to the input of the frequency converter. Formation of the voltage form at the inverter input is carried out by dividing into several steps with different voltage levels, and program-controlled switching time. The transistor inverter was assembled by a bridge circuit. The bridge circuit consists of four transistors (figure 7). At certain points in time, at each stage it is necessary to switch a pair of transistors to form a positive and negative half-wave of a sinusoidal voltage. The switching mode of the transistors is organized in such a way as to exclude a short circuit of voltage sources.

**Conclusion.** SKYPER 52 drivers will be used in transistor frequency converters of induction heating, which is the conversion of a low-current logic controller signal into a gate control signal, the power of which should be sufficient for quick recharging of IGBT shutter capacities. Since the power switches operate at voltages significantly exceeding the potentials of the controller signals, the gate control device must carry out a high-voltage level shift or galvanic isolation of control pulses and pulses arriving at the gates. In addition, the modern SKYPER 52 drivers contain numerous protective and service functions necessary for IGBT uptime in all operating modes, including emergency.

**Н. Т. Исембергенов<sup>1</sup>, А. Ж. Сагындиқова<sup>2</sup>, П. Даскалов<sup>3</sup>**

<sup>1</sup>Satbayev University, Алматы, Қазақстан;

<sup>2</sup>Гумарбек Даукеев атындағы Алматы энергетика және байланыс университеті, Алматы, Қазақстан;

<sup>3</sup>Ангел Кънчев атындағы Русе университеті, Русе, Болгария

## ТӨМЕНГІ ӨНДІРУ ҰҢҒЫМАЛАРЫНДА МҰНАЙ ҚЫЗДЫРУДЫҢ ИНДУКЦИЯЛЫҚ ӘДІСІ

**Аннотация.** Мақалада төменгі өндіру ұңғымаларында мұнай қыздырудың индукциялық әдісі қарастырылады. Ол үшін индукциялық қыздырғыш пен жиілік түрлендіргіш пайдалануды ұсынады. 1-1,5 кГц ток жиілігі кезінде индукциялық қыздырғыш және инвертор жиілік түрлендіргіші мұнай ұңғымасының түбінде орнатылуы мүмкін. Инвертор бір мың вольтке дейін кернеу, жүздеген ампер және ондаған киловатт қуат тогы коммутациялайтын JGBT транзисторлық модуляцияларда орындалады.

Мұнайды жылыту үшін шағын, қызмет көрсетуге ыңғайлылық пен арзан электр энергиясы болған кезде пайда болатын электр жылыту құрылғылары қолданылады.

Жүргізілген зерттеулердің мақсаты – мұнайды қажетті температураға дейін жұмсалатын электр энергиясын барынша тиімді пайдалана отырып, ашық отты (пеш, жанарғы) қолданбай, жылу электр қыздырғыш аспаптарынсыз (ТЕН) және ПЭК 60-80% аспайтын жылу алмастырғыш құрылғыларды қолданусыз қыздыру. Бұл индукциялық қыздыру әдісін пайдалану барысында жүзеге асырылады.

Индукциялық қыздыру технологиялық жабдықты (мұнай құбыры, құбыр, сыйымдылық және т.б.) жылыту, сұйық ортаны қыздыру, материалдардың (мысалы, сүрек) жабынын кептіру үшін қолданылады. Индукциялық қыздыру кондырғыларының маңызды параметрі – жиілік. Әрбір үдеріске үздік технологиялық

және экономикалық көрсеткіштерді қамтамасыз ететін оңтайлы жиілік диапазоны бар. Индукциялық қыздыру үшін 50Гц-тен 5МГц-ке дейінгі жиілік қолданылады.

Мұнай өндіруді ұлғайту үшін мұнай жылытуды жүзеге асыру қажет. Бұл көптеген мұнай өндіруші компанияларда маңызды әрі жан жақты мәселе болып саналады. Жылыту үшін су буы, ыстық су, ыстық газ және мұнай өнімдері, электр энергиясы сынды түрлі жылу тасымалдағыштар қолданылады. Жоғары жылу мөлшері мен жылу бергіші бар, жай ғана тасымалданатын және өрт қаупі жоқ су буы көп қолданылады. Мұнай өнімін 80-100°C дейін қыздырып, 0,3 - 0,4 МПа қысымдағы қаныққан буды пайдаланады.

Мұнай ұңғымаларындағы мұнайды қыздырудың мұндай тәсілі Латын Америкасы елдерінде қолданылады. Әдебиеттер мен құжаттаманы шолу әрі талдау жұмыстары көрсеткендей, жылытқыштың шетелдік конструкциясының үлестік құны өте жоғары. Осыған байланысты Қазақстанда шетелдік өндіріс жылытқышын енгізген тиімсіз саналады, өйткені өтелімділік мерзімі он жылға жетеді. Сондықтан индукциялық жылытқышын экономикалық жағынан тиімді болатын өзіне тән әзірлемелер негізінде жетілдіру қажет. Электр энергиясының құны шетелдегі электр энергиясының құнымен салыстырғанда төмен болған жағдайда, сондай-ақ бүкіл қондырғының үлестік құнын төмендету, индукциялық жылытқышты әзірлеу және енгізу өзекті мәселе болып саналады.

Техникалық құжаттаманы әзірлеу кезінде жиілік түрлендіргішінің зертханалық үлгісін жасау және транзисторлық JGBT модульдерді таңдау кезінде басты назар модульдің күштік шиналарының топологиясына және электр тізбектерін қосу және жылуды бұру тәсілдеріне аударылды. Қазіргі заманғы чиптерді қолданғанда да қуатты негізгі модульдердің конструкциясы сенімділік пен тиімділікті қамтамасыз етуде өте маңызды. Байланыс шиналары мен шығарылған өткізгіштігінің бөлінген сипаттамасы мен паразиттік индуктивтілігінің мәні ысырапты азайту мен ауыспалы кернеудің арту деңгейін төмендету үшін аз мәнге ие болуы тиіс.

Сонымен қатар, тәжірибелік жолмен с конденсаторының мәнін таңдай отырып, шығу кернеуінің сапасын жақсартып қана қоймай, дәйекті резонансқа қол жеткізуге болады. Резонанс кезінде инвертордың белсенді қуаты индукторға беріледі, яғни қыздыру үшін дайын болады.

**Түйін сөздер:** индукциялық әдіс, ток жиілігі, JGBT транзисторлық модульдері, кернеу, қажетті температура.

**Н. Т. Исембергенов<sup>1</sup>, А. Ж. Сағындықова<sup>2</sup>, П. Даскалов<sup>3</sup>**

<sup>1</sup>Satbayev University, Алматы, Қазақстан;

<sup>2</sup>Алматинский университет энергетик и связи им. Гумарбека Даукеева, Алматы, Қазақстан;

<sup>3</sup>Университет Русь Ангел Канчев, Русе, Болгария

### **РАЗРАБОТКА И ИССЛЕДОВАНИЕ ПРЕОБРАЗОВАТЕЛЯ ЧАСТОТЫ С ИНТЕЛЛЕКТУАЛЬНОЙ СИСТЕМОЙ УПРАВЛЕНИЯ С ИНДУКЦИОННЫМ НАГРЕВАТЕЛЕМ**

**Аннотация.** В статье рассматривается индукционный способ нагрева нефти в низкодебитных скважинах. Для этого предлагают использовать индукционный нагреватель и преобразователь частоты. Показано, что при частотах тока 1 – 1,5 кГц индукционный нагреватель и инвертор-преобразователь частоты могут быть установлены на дне нефтескважин. Инвертор будет выполнен на JGBT транзисторных модулях, которые могут коммутировать напряжения до тысяча вольт, токи – сотни ампер и десятки киловатт мощности.

Для подогрева нефти используют электронагревательные устройства, которые различаются компактностью, удобством в обслуживании и выгодой при наличии дешевой электроэнергии.

Цель проводимых исследований – нагрев нефти до необходимой температуры, с максимально эффективным использованием затрачиваемой электроэнергии, без применения открытого огня (печи, горелки), без тепловых электронагревательных приборов (ТЭНов) и без использования теплообменных устройств, КПД которых не превышает 60-80%. Это возможно при использовании индукционного способа нагрева.

Индукционный нагрев применяют для обогрева технологического оборудования (нефтепровода, трубопровода, емкости и т. д.), нагрева жидких сред, сушки покрытий материалов (например, древесины). Важнейший параметр установок индукционного нагрева – частота. Для каждого процесса существует оптимальный диапазон частот, обеспечивающий наилучшие технологические и экономические показатели. Для индукционного нагрева используют частоты от 50Гц до 5МГц.

Для увеличения добычи нефти необходимо осуществить подогрев нефти. Это многогранная и серьезная проблема для многих нефтедобывающих компаний. Для обогрева используют разные теплоносители: водяной пар, жаркую воду, жаркие газы и нефтепродукты, электроэнергию. Наибольшее применение имеет водяной пар, обладающий высочайшим теплосодержанием и теплоотдачей, просто транспортируемый и не

представляющий пожарной угрозы. Употребляют насыщенный пар давлением 0,3-0,4 МПа, обеспечивая нагрев нефтепродукта до 80-100 °С.

Такой способ нагрева нефти в нефтескважинах применяется в странах Латинской Америки. Как показывает обзор и анализ литературы, а также технические документации, удельная стоимость существующих зарубежных конструкций нагревателей очень высока. В связи с этим, внедрение нагревателей в Казахстане иностранного производства невыгодно, так как срок окупаемости достигает около десяти лет. Поэтому следует разрабатывать свои индукционные нагреватели на основе собственных разработок, которые будут экономически выгодны. Учитывая, что при низкой стоимости электроэнергии по сравнению со стоимостью электроэнергии за рубежом, а также снижение удельной стоимости всей установки разработка и внедрение индукционных нагревателей является актуальной проблемой.

При разработке технической документации для изготовления лабораторного образца преобразователя частоты и выборе транзисторных JGBT модулей основное внимание было уделено топологии силовых шин модуля и способам подключения электрических цепей и отвода тепла. Даже при использовании самых современных чипов конструкция мощных ключевых модулей имеет чрезвычайно большое значение для обеспечения надежности и эффективности. Распределенные характеристики проводимости и значения паразитных индуктивностей шин связи и выводов должны иметь минимальное значение для уменьшения потерь и снижения уровня переходных перенапряжений.

Кроме того, подбирая экспериментальный путем значение конденсатора С можно не только улучшить качество выходного напряжения, но и добиться последовательного резонанса. При резонансе активная мощность инвертора будет передаваться индуктору, т.е. заготовке для нагрева.

**Ключевые слова:** индукционный метод, частота тока, транзисторные модули JGBT, напряжение, требуемая температура.

#### **Information about authors:**

Isembergenov Nalik Turegalievich, Professor of the department at «Satbayev University» (Kazakh National Research Technical University named after K.I. Satpayev), doctor of technical science, professor, Almaty, Kazakhstan; isembergenov@mail.ru; <https://orcid.org/0000-0001-7631-8881>

Sagyndikova Aigul Zhursinkyzy, Professor of the department «Automation and control» (Gumarbek Daukeev Almaty University of Energy and Communications), PhD, professor, Almaty, Kazakhstan; sagyndikova\_aigul@mail.ru; <https://orcid.org/0000-0001-9988-5694>

Daskalov Plamen, University of Ruse Angel Kanchev | UR · Department of Automation and Mechatronics Professor, Ph.D., Ruse, Bulgaria; <https://orcid.org/0000-0003-1568-8058>

#### **REFERENCES**

- [1] Kuvaldin A.B. Induction heater of ferromagnetic steel. M.: Energoatomizdat, 1988. 188 p.
- [2] Multistage transistor inverter (options). No. 60621: Copyright certificate on the Patent. Committee on Intellectual Property Rights of the Ministry of Justice of the Republic of Kazakhstan. Bull. No. 9 on 07/15/2009
- [3] A frequency converter with two transistors for electrical technology // XIV Mezhdunar. conf. "Electromechanics, Electrotechnologies, Electrotechnical Materials and Components". Crimea: Alushta, 2012.
- [4] Transformerless inverter (options). No. 73453: Copyright certificate for a patent. Committee on Intellectual Property Rights of the Ministry of Justice of the Republic of Kazakhstan. Bull. No. 3 dated 03/15/2012.
- [5] Isembergenov N.T., Sagyndikova A.Zh., Nauhan A.M. Transistor frequency converter for induction heating of metal.
- [6] Isembergenov N.T. A frequency converter for induction heating of an oil pipeline with three-phase power // Patent number 99534. Copyright certificate for an innovative patent. Committee on the Rights of Intellectual Property of the Ministry of Justice of the Republic of Kazakhstan. Almaty: 2017. Bull. N 18.
- [7] Isembergenov N.T. Multistage transistor inverter for converting solar energy - "Electricity". 2011. N 7. P. 12-17.
- [8] Isembergenov N.T. Power frequency converter on IGBT transistors. Ural Radio Engineering Journal. Russia, Yekaterinburg. 2018. N 1. P. 59-66.
- [9] Federal business magazine "Business & Class". M., 2016. N 1. P. 16-19.
- [10] Kopylov I.P. Design of electrical machines. M.: Yurayt, 2015. 300 p.
- [12] Lysakov A.A. Electrotechnology: Lecture course, study guide. Stavropol, World, 2013. 124 p.
- [13] Vogel A.A., Induction Method for Holding Liquid Metals in Suspension, Leningrad: Mechanical Engineering, 1989. 79 p.
- [14] Mitkov A. Theory of the experiment. Ruse: Dunav pres, 2011. 227 p.
- [15] Automation and telemechanics systems on the world's railways. Textbook for high schools. Transport // Trans. from English; under the editorship of G. Teega, S. Vlasenko. M.: Intext, 2010.
- [16] Isembergenov N.T., Sagyndikova A.Zh. Temperature Distribution in a Grain-Dryer With Induction Heaters. International Conference on Agricultural, Civil and Environmental Engineerin (ACEE-16) Istanbul, Turkey, April 18-19, 2016. P. 58-60.
- [17] Sagyndikova A.Zh., Dzhamburshyn A.S., Atyhanov A.K., Beloevand H., Daskalov P. Intensive Energy Saving Method of Grain Drying. Bulgarian Journal of Agricultural Science (BJAS). Received April, 6, 2015; accepted for printing February, 19, 2016

**Publication Ethics and Publication Malpractice  
in the journals of the National Academy of Sciences of the Republic of Kazakhstan**

For information on Ethics in publishing and Ethical guidelines for journal publication see <http://www.elsevier.com/publishingethics> and <http://www.elsevier.com/journal-authors/ethics>.

Submission of an article to the National Academy of Sciences of the Republic of Kazakhstan implies that the described work has not been published previously (except in the form of an abstract or as part of a published lecture or academic thesis or as an electronic preprint, see <http://www.elsevier.com/postingpolicy>), that it is not under consideration for publication elsewhere, that its publication is approved by all authors and tacitly or explicitly by the responsible authorities where the work was carried out, and that, if accepted, it will not be published elsewhere in the same form, in English or in any other language, including electronically without the written consent of the copyright-holder. In particular, translations into English of papers already published in another language are not accepted.

No other forms of scientific misconduct are allowed, such as plagiarism, falsification, fraudulent data, incorrect interpretation of other works, incorrect citations, etc. The National Academy of Sciences of the Republic of Kazakhstan follows the Code of Conduct of the Committee on Publication Ethics (COPE), and follows the COPE Flowcharts for Resolving Cases of Suspected Misconduct ([http://publicationethics.org/files/u2/New\\_Code.pdf](http://publicationethics.org/files/u2/New_Code.pdf)). To verify originality, your article may be checked by the Cross Check originality detection service <http://www.elsevier.com/editors/plagdetect>.

The authors are obliged to participate in peer review process and be ready to provide corrections, clarifications, retractions and apologies when needed. All authors of a paper should have significantly contributed to the research.

The reviewers should provide objective judgments and should point out relevant published works which are not yet cited. Reviewed articles should be treated confidentially. The reviewers will be chosen in such a way that there is no conflict of interests with respect to the research, the authors and/or the research funders.

The editors have complete responsibility and authority to reject or accept a paper, and they will only accept a paper when reasonably certain. They will preserve anonymity of reviewers and promote publication of corrections, clarifications, retractions and apologies when needed. The acceptance of a paper automatically implies the copyright transfer to the National Academy of Sciences of the Republic of Kazakhstan.

The Editorial Board of the National Academy of Sciences of the Republic of Kazakhstan will monitor and safeguard publishing ethics.

Правила оформления статьи для публикации в журнале смотреть на сайте:

[www.nauka-nanrk.kz](http://www.nauka-nanrk.kz)

**ISSN 2518-170X (Online), ISSN 2224-5278 (Print)**

<http://www.geolog-technical.kz/index.php/en/>

Редакторы *Д. С. Аленов, М. С. Ахметова, Т. А. Апендиев*  
Верстка *Д. А. Абдрахимовой*

Подписано в печать 12.06.2020.  
Формат 70x881/8. Бумага офсетная. Печать – ризограф.  
13,6 п.л. Тираж 300. Заказ 3.